

# Development of an evaporative cooling system applied to the air conditioning of urban buses

César Ramos Broliato\*, Carlos Roberto Altafini\*, Carlos Alberto Costa\*

## Abstract

Air conditioning for buses is an important incentive tool for the public transport, since it offers comfort to passengers and stimulates the use of this kind of transport which is fundamental to improve urban mobility. Currently, air conditioning equipment for buses is the mechanical vapor compression (MVC) type. However, this kind of system has two main disadvantages: the high financial cost and power consumption by the vehicle engine. The purpose of this study is to develop an evaporative cooler for buses, which is a simple, environmental friendly, low-cost solution that does not use engine power for its operation. The first step was the design and construction of the prototype. The following step was to evaluate the built prototype through performing experimental tests. The prototype presented a saturation efficiency of approximately 70%, airflow rate of 421.5 m<sup>3</sup>/h and energy consumption of 98.4 W. After determining the prototype technical characteristics, the evaporative cooling system was developed for an urban bus, seeking to meet the air renewal required by ANSI/ASHRAE standard 62.1 and to promote the passenger's thermal comfort as specified by ISO 7730 and ANSI/ASHRAE Standard 55. The thermal comfort provided by the new cooling system was evaluated through the PMV-PPD indexes. A value of 0.35 was obtained for the PMV index and the PPD index obtained a value of 7, indicating that approximately 93% of the passengers will be satisfied regarding their thermal comfort for the established environmental conditions. The evaporative cooling system had a total energy consumption of approximately 0.4 kW, which represents only 5% of the energy that would be consumed by a MVC system. Therefore, the evaporative cooling performance depends on the climatic conditions of the environment, especially humidity. However, when applied in favorable conditions (low humidity), the evaporative cooling system proved to be a viable solution to replace the MVC systems in buses air-conditioning application, where its main advantage is its positive cost-benefit and energy savings.

## Keywords

Evaporative cooler. Air-conditioning. City bus. Thermal comfort. Saturation efficiency.

## List of Symbols

$T_{WB}$	Wet bulb temperature [°C]
$T_{DB}$	Dry bulb temperature [°C]
$\phi$	Relative humidity [%]
$\varepsilon$	Saturation efficiency [%]
$clo$	Clothing insulation [m <sup>2</sup> ·K/W]
$met$	Metabolism rate [W/m <sup>2</sup> ]
$T_O$	Operative temperature [°C]
$T_{MR}$	Mean radiant temperature [°C]
$T_{insf}$	Prototype insufflation temperature [°C]
$\Delta T$	Prototype temperature reduction [°C]

## List of Abbreviations

ASHRAE	American Society of Heating, Refrigerating and Air Conditioning Engineers
ANSI	American International Standards Institute
MVC	Mechanical compressor of vapor
ISO	International Organization for Standardization
PMV	Predicted Mean Vote
PPD	Predicted Percentage of Dissatisfied
DEC	Direct evaporative cooling
RPM	Rotations per minute
SD	STANDARD DEVIATION

## I. INTRODUCTION

According to ANSI/ASHRAE standard 55 [1], thermal comfort can be defined as a condition of mind that expresses satisfaction with the thermal environment. This thermal comfort state is achieved when the body reaches a balance between the heat generated through metabolism and the heat lost to the environment. The greater the adaptation effort of the organism, the greater is the sensation of thermal discomfort, contributing to the people's stress and fatigue. An air-conditioned environment provides comfort, health and welfare for its users [2].

The public transport sector is increasingly concerned about thermal comfort of its passengers, either to meet the big cities standards, which regulate public transportation, or to get an advantage in the competitive public transport market, where to offer an air-conditioned transportation service is an important selling tool that helps in attracting new users.

The current air conditioning system for vehicles is a Mechanical Vapor Compression (MVC) type. Four principal components compose this kind of system: evaporator, condenser, expansion valve and compressor. The compressor is the main component of the MVC system and is considered the heart of this type of equipment. However, the compressor needs a lot of energy to compress the refrigerant gas, extracting from the vehicle's powertrain the required energy for its operation. This extra consumption is

\* Área do Conhecimento de Ciências Exatas e Engenharia – Universidade de Caxias do Sul

E-mails: mavailatti@ucs.br, craltafi@ucs.br, gdtelli@ucs.br, js-rosa@hotmail.com

Data de envio: 28/03/2020

Data de aceite: 18/11/2020

an undesirable situation, due to issues related to energy efficiency, greenhouse gases emission and autonomy (especially for electric vehicles case), once energy saving is becoming increasingly important in the new vehicles design. However, even harmful, the energy consumption increases to promote the vehicle thermal comfort is an indispensable condition to meet customer expectations. Therefore, it is important to develop new energy efficient air conditioning systems, which aim to reduce the energy consumption by the vehicle engine, improving its performance as a whole [3].

In addition to the high-energy consumption, the buses MVC equipment presents yet another great disadvantage which is its high financial cost. In order to obtain a lower selling price, a large number of new buses without any kind of air conditioning system are purchased and manufactured. However, such option will not offer the adequate thermal comfort for its passengers.

An alternative to MVC air conditioning system, with lower cost and lower energy consumption, is the evaporative cooling technology. According to Datta et al. [4], evaporative cooling is a simple process, which shows an energy saving of up to 75% when compared to MVC systems, as well as lower maintenance and installation costs. It consists of a clean and renewable process where air and water are the working fluids, and the water evaporation is used to reduce air temperature, increasing the thermal comfort of the environment.

Currently, evaporative cooling is mainly used for industrial and agricultural areas, such as water-cooling towers, air washers, humidifiers, evaporative condensers, greenhouses and also to reduce the temperature in places where several heat sources are present. However, despite having great potential, it still has a low exploitation for air conditioning and human thermal comfort [5].

Knowing the cooling potential of this kind of system this study aims to develop a new equipment that uses evaporative cooling to promote thermal comfort in a public transport urban bus.

The urban transport application was chosen because this kind of bus presents constant opening of doors and windows. This condition is beneficial for the evaporative cooling system, because this method requires air renewal. During the cooling process, air is humidified, requiring its renewal to avoid the environment moisture saturation. The proposed system will replace the foul indoor air for new clean and cooled air, eliminating pollutants, germs, smoke, odors and dust.

Therefore, the evaporative system combined with an efficient air circulation design presents a great cooling potential for urban collective transportation, being an economic and ecological alternative to replace MVC systems.

## EVAPORATIVE COOLING

Evaporative cooling is a simple and environment friendly air conditioning technique with a high-energy efficiency. This kind of system is able to provide a cooled air with suitable temperature and humidity, presenting a low energy consumption, where its results will be better as much drier the environment is.

There are two types for evaporative cooling equipment construction. For the first, called Direct Evaporative Cooling (DEC), the air stream comes into direct contact with the water, raising its moisture and decreasing temperature. For the Indirect equipment the air is cooled by a secondary air current, which has been previously cooled by the direct process. The interface between both air streams occurs through a heat exchanger, that is, without the direct contact to the water. Thus, the indirect process does not increase the humidity in the air flow, however its efficiency is lower than the DEC, in addition to the greater complexity for its equipment [2].

The direct evaporative cooler device has a simplified construction, as showed in Figure 1, consisting basically in a cabinet to cover the components, reservoir tank, blower or a fan, pump for water circulation and some wetted medium that promotes the contact area increase between air and water, being evaporative pads commonly used [6].

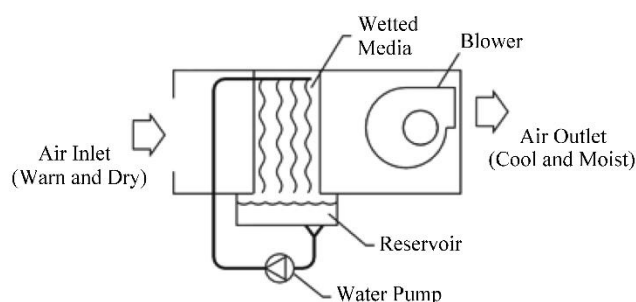

Figure 1: DEC device schematic

Evaporative cooling has as its operating principle the water evaporation and the exchange of sensible heat by latent heat. When unsaturated air and water come into contact, a simultaneous phenomenon of heat and mass transfer occurs. The mass transfer will occur through evaporation, which requires energy for the process to happen. Therefore, the required energy for the evaporation is supplied by the surrounding air and by the water itself, where its molecules near of surface will be evaporated when they receive energy from the bulk fluid. As a result, air and water are cooled during this process, supplying sensible heat that will be converted into latent heat, so that water state change (evaporation) happens [7].

If the contact between unsaturated air and water is free, for a long time and occurs adiabatically, then the final result will be an equilibrium condition, where air absorbs moisture until it is fully saturated and both fluids will be at the same temperature. At this point, there will be no more heat exchange ways, and the final temperature of both fluids will be equal to the wet-bulb temperature ( $T_{WB}$ ). Thus, if the air is cooled until the  $T_{WB}$  of environment, it will be completely humidity saturated, and the evaporative cooling process will be 100% effective, reaching its maximum saturation efficiency ( $\epsilon$ ). This process is named adiabatic saturation [8].

The limit for evaporative cooling is represented by  $T_{WB}$  value, because considering theoretical and ideal conditions, it will be the lowest temperature that will be possible to reach. Therefore, the drier the environment is the better the evaporative cooling performance will be, because this kind of environment present a lower  $T_{WB}$  allowing air to be cooled to a lower temperature [9].

Therefore,  $\varepsilon$  is a key factor to determine the performance of an evaporative cooler equipment, and it can be calculated with the aid of Eq. 1. In practice, commercial DEC equipment has a saturation efficiency between 85% and 95% [10].

$$\varepsilon = 100 \cdot \frac{T_{DB,i} - T_{DB,o}}{T_{DB,i} - T_{WB,i}} \quad (1)$$

where  $\varepsilon$  is the saturation efficiency [%],  $T_{DB,i}$  is the dry bulb temperature of inlet air [°C],  $T_{DB,o}$  is also the dry bulb temperature, however for the outlet air [°C] and  $T_{WB,i}$  is the wet bulb temperature of inlet air [°C].

Airstream cooled by a DEC leaves the equipment carrying moisture into the environment, increasing its relative humidity ( $\phi$ ). Therefore, the fundamental condition for the proper functioning of an evaporative system is the total renewal of the environment internal air [8].

**THERMAL COMFORT**

From the point of view of thermal comfort, the human body can be considered a thermodynamic system that produces heat. This heat must be rejected in order to the body reach the indispensable thermal balance that keeps itself operating. Thus, there is a constant heat exchange between the human body and the environment, governed by the physics laws and influenced by environmental conditions and individual factors. In consequence, the thermal comfort state is obtained when the human organism loses to the environment, without resorting to biological mechanisms of thermoregulation, the heat produced by its metabolism compatible with its activity [11].

According to Parsons [12], six primary factors define the thermal comfort conditions. These factors may be of personal origin or related to environmental variables. The primary factors are: metabolic rate, clothing insulation, air temperature, radiant temperature, air speed and humidity. The first two factors are related to personal parameters, while others are associated with environmental conditions. There are also several secondary factors of minor importance, which can affect thermal comfort in some situations. These factors can be gender, age, localized discomfort, eating habits, cultural aspects, etc.

Due to this great number of variations, physical as well as psychological, which vary from person to person, it is difficult to satisfy everyone in one space. The thermal comfort is assessed by subjective evaluation and the environmental conditions required to get this state are not the same for everyone. Extensive laboratory and field data have been collected and provide the necessary statistical data to define conditions that probably will satisfy most people in a specific environment. All this information was gathered and used to develop thermal comfort indexes [1].

The thermal comfort indexes were developed from the need to know the thermal sensation experienced by people exposed to environmental and personal variables. These indexes seek to encompass, in a single parameter, the combined effect of these variables. In general, the indexes set the value of some variable such as the type of activity and the clothing used by the individual, for later relating the environment variables and gathering, in the form of letters or

graphics, the various environmental conditions that provide equal responses for the individuals [11].

There are many thermal comfort indexes, each one being more suitable in some particular situation or type of region climate. For the present study, the PMV-PPD index is considered, since these are the thermal comfort indexes adopted by the international standards ISO 7730 and ANSI/ASHRAE Standard 55.

The Predicted Mean Vote (PMV) index is based on a scale that has seven points (+3 hot, +2 warm, +1 slightly warm, 0 neutral, -1 slightly cool, -2 cool, -3 cold) that expresses the thermal sensation of satisfaction experienced by a person [13]. The PMV equation was developed through the votes collected during the realization of several experiments in air-conditioned chambers that have evaluated the satisfaction level of individuals exposed to the most diverse environmental conditions. This index uses heat balance principles to relate the key factors of the thermal comfort, allowing predicting the comfort response for a group of people, based on the previous scale [2].

The Predicted Percentage of Dissatisfied (PPD) index evaluates the percentage of votes related to the occupants' dissatisfaction with the thermal comfort offered by the environment. In this way, the PPD is based on people who voted +2, +3, -2, or -3, which is, people who felt dissatisfaction (heat or cold) about their thermal sensation. This index is directly related to the PMV, so that its value is estimated based on the value obtained for the PMV [13]. Figure 2 shows the graph that relates the PPD values as a function of the obtained value for the PMV.

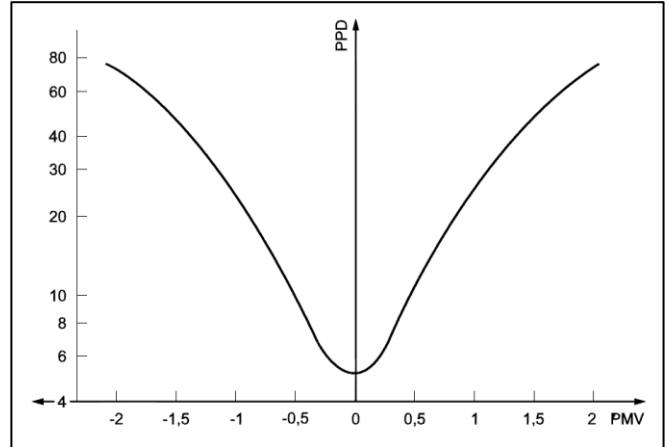

Figure 2: PPD value as a function of PMV value

However, the  $T_{DB}$  of air cannot be applied directly in PMV-PPD indexes calculations. It is also necessary to consider the effects of radiation on thermal sensation. This consideration can be done through the Mean Radiant Temperature ( $T_{MR}$ ). The PMV-PPD indexes are based on an average temperature resulting from the combination between ambient air  $T_{DB}$  and its  $T_{MR}$ , named Operative Temperature ( $T_o$ ). Then,  $T_o$  is the temperature that should be used for all calculations and considerations regarding PMV-PPD thermal comfort indexes [12].

In cases of environments without significant sources of radiation, such as, not directly exposed to solar radiation, fireplaces, electric heaters, combustion engines or major heat

generating equipment, it is possible to directly assume that  $T_O$  is equal to  $T_{DB}$  air [1].

The standard ISO 7730 [13] specifies that air velocity influences the convective heat exchange between occupants and environments, influencing the thermal comfort of the body. There is no minimum velocity required for comfort, but the speed increase can be used to compensate the sensation of heat when the temperature in a certain environment increases.

The lower the temperature difference between the environment and the cooled airstream the higher the air velocity should be to help to promote the temperature reduction sensation. Evaporative cooling usually provides insufflation air with a lower temperature reduction than MVC systems, so higher air velocities are allowed for environments cooled by a DEC equipment. In that case, velocities of 1.5 m/s are usually adopted for the internal air circulation [14].

ISO 7730 [13] presents in its scope the mathematical model that allows to calculate the PMV and PPD indexes based on the variables of thermal comfort. In addition, the standard also presents a set of tables and graphs for different combinations of metabolism (met), clothing (clo),  $T_o$  and air velocity (v), which make it possible to obtain the PMV index directly, without the need for calculations.

The standards ISO 7730 and ANSI/ASHRAE Standard 55 assume that the thermal comfort zone is one in which the value for the PMV index is within the range of -0.5 to +0.5, and the value for the PPD index is less than 10 %.

## RELATED STUDIES

Delfani et al. [15] conducted experiments to verify the efficiency of a dual-stage air conditioning system, using an evaporative cooling unit (DEC) prior to a mechanical cooling unit (MVC). When performing the tests simulating conditions for different cities in Iran, the authors found a 55% average reduction in electric energy consumption compared to the conventional MVC system.

Alahmer [16] proposed an automotive air conditioning composed by an evaporative cooler combined with desiccant wheel and a regenerator, in order to provide a comfortable environment inside the car cabin with minimum energy consumption. The thermal analysis of the proposed system presented a coefficient of performance (COP) of 0.7 to 0.9 as result. This low COP does not mean that the system is inefficient since the COP calculation takes into account the regeneration heat that was wasted. Then, the real power consumption is the electrical power consumed which produces a COP of about 3.5 to 4.5. The main remark is that evaporating cooling system is more efficient than the conventional air conditioning when the gasoline price is more than 0.34 \$/liter.

Thakur and Bergaley [17] seek in the evaporative cooling a solution to replace the use of MVC air conditioning systems for commercial and transportation vehicles. The results showed that the cooling capacity of the DEC system was lower than conventional air conditioning. However, the evaporative system still had satisfactory cooling results for the studied regions in India, with the advantage of a large fuel economy and energy savings, which reduced the transportation cost and the emission of pollutants. Therefore,

the DEC may be preferred to replace the MVC system. The results indicated a better performance if the cabin windows remained partially open, because the total window closure may cause discomfort due to humidity increase.

Kushwaha and Tiwari [18] concentrated their research on thermal comfort for a tractor cabin, using the evaporative cooling, which is an economic and eco-friendly alternative. The prototype performance reduced cabin temperature near to the acceptable comfort limits, with less than 10% of power consumption in comparison to MVC units, when tested under the same weather conditions. The authors observed that with the new evaporative cooling system, tractor cabin may act like a greenhouse when it is closed, and its interior may become uncomfortable for the driver. Therefore, it is extremely important to have at least a partial opening in the window of the tractor for air renewal.

## II. MATERIALS AND METHODS

The current air conditioning system for bus is the MVC type. Usually, this equipment is installed in the bus roof and the air cooled by the equipment is distributed inside the vehicle through ducts. These ducts are positioned along the bus body length, as shown in Figure 3. The compressor is connected to the engine pulley by belts, removing from the vehicle the work necessary for its operation [19]. Based on compressor performance curve of a typical bus air conditioner, the mean power consumption is 8.0 kW for the compressor model FKX40/655, operating with 1500 RPM [20].

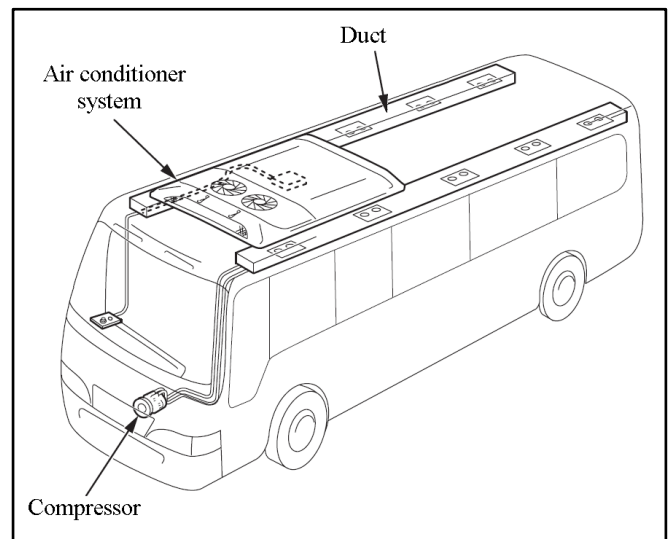

Figure 3: Current bus air conditioning system  
Evaporative cooler design

The goal for the new air conditioning equipment is to provide a solution with lower financial cost and which does not use the engine power for its operation. Thereby, the purpose of this study was to replace the MVC equipment by a system, which reduce the air temperature through the evaporative cooling. The evaporative cooler design, developed for this study, is presented in Figure 4, where the main components are:

- upper housing (1);
- water reservoir (2);

- internal base (3);
- grilles (4);
- upper cover (5);
- fan's cover (6);
- axial fan (7);
- electro pump for water circulation (8);
- water level sensor (9);
- fixing bolts (10).

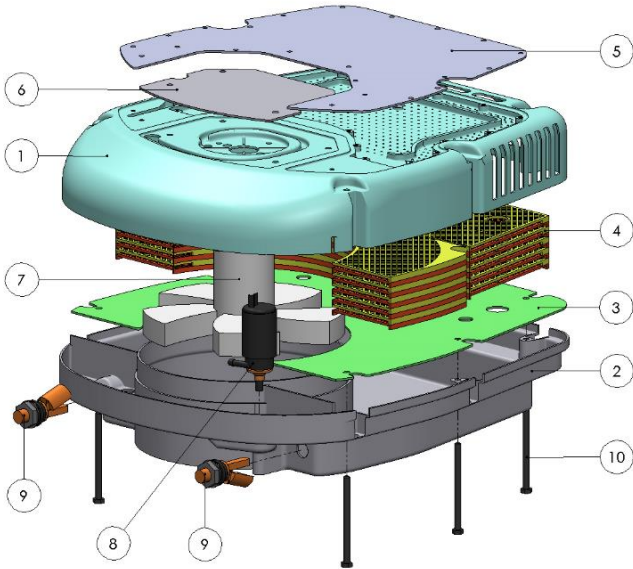

Figure 4: Prototype main components

The housing (1), reservoir (2) and grilles (4) were built through rapid prototyping, using 3D printing technology *Fused Deposition Modeling*. The internal base (3) and covers (5 and 6) were made with aluminum sheet cut by laser cutting machines. The components such as fan (7), electric pump (8), sensors (9) and bolts (10) were purchased in the market. The prototype is shown in Figures 5 and 6.



Figure 5: Prototype of the evaporative cooler closed



Figure 6: Prototype of the evaporative cooler opened

The air cooler equipment draws the outside air, cools the airstream in its interior and then blows the cooled air into the bus. The contact between air and water, required for evaporative cooling, takes place internally through the grilles shown in Figure 7.

The grilles function is to increase the contact area between air and water. This is possible because its shape is like a braided grid, and this kind of geometry has the ability to retain water on its surface. The outdoor air is forced to pass through the grilles, cooling itself when evaporating the water on the grilles surface. The electric pump has the purpose of elevating the water from the reservoir to the top of the equipment, which will be dripped on the grilles, keeping the moisture required for the evaporative cooling.



Figure 7: Grille responsible for the increase of air and water contact area

The prototype is installed externally on the vehicle ceiling. A cut in the ceiling is necessary in order to allow the cooled airflow to enter in the bus body. Figure 8 shows the installation of the equipment on the bus.

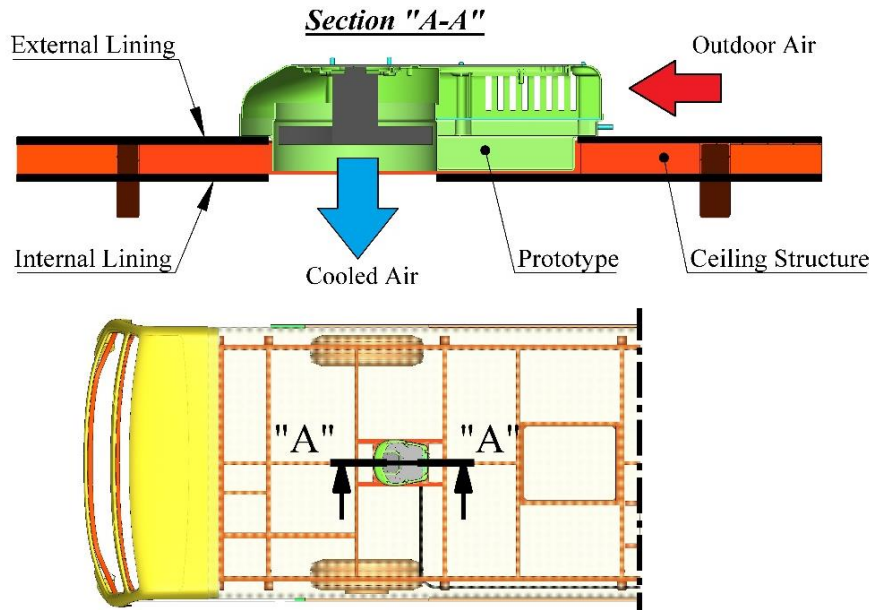

Figure 8: Installation of the evaporative cooler on the ceiling of the vehicle

#### PROCEEDINGS FOR THE PROTOTYPE EVALUATION

The performance of the prototype was evaluated through bench experiments. The main characteristics determined were the saturation efficiency and airflow rate of the equipment. In order to obtain these parameters, the following measuring instruments were used:

- thermo-hygro-anemometer. Model 4000 Delta T, from Kestrel (Speed Accuracy:  $\pm 3\%$  [m/s]).
- two thermo-hygrometers. Model MT-241, from Minipa (temperature accuracy:  $\pm 1$  [°C] and  $\varnothing$  accuracy:  $\pm 5\%$ ).

During the experiments, it was taken care in order to prevent the contact between the air cooled by the prototype and the testing environment. This is necessary because the air stream cooled by the prototype would change the temperature and humidity of the testing environment when mixed with the air of the place where the experiment is being performed, influencing the results.

To avoid such situation, the prototype was assembled inside a closed and insulated wooden box, with dimensions of  $600 \times 650 \times 750$  mm. Therefore, the box interior was the controlled testing environment, where the temperature and humidity were monitored. The prototype was assembled in such way that the cooled air is blown out without having contact with the box interior.

To conditioning the box interior, an electric heater with 2.0 kW of power was used, and it was connected to the box through a flexible duct. In order to monitor the internal temperature and humidity, the two thermo-hygrometer sensors were used: the first (sensor 1) was positioned near the prototype air intake region, while the second (sensor 2) was positioned at the box central point, to verify the average temperature inside this environment. The sketch for the bench experiment and its execution are shown in Figures 9 and 10.

The results of evaporative cooling depend on environmental aspects, especially humidity. In this way, the prototype was experimented in three different situations of relative humidity ( $\varnothing$ ), aiming to know its behavior for different climatic conditions:

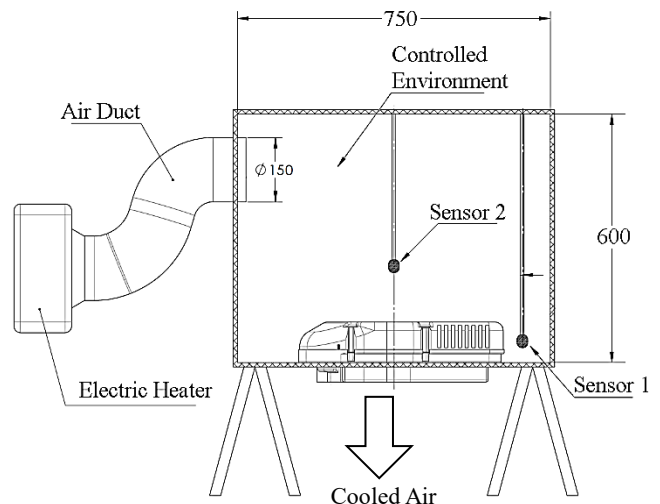

Figure 9: Sketch for the bench experiment

- favorable condition -  $\varnothing$  is equal to 25%;
- medium condition -  $\varnothing$  is equal to 50%;
- adverse condition -  $\varnothing$  is equal to 75%.

To evaluate the prototype saturation efficiency, the following procedures were performed:

- heating or cooling down the box interior until the relative humidity reaches the value specified for the test;
- after reaching the desired relative humidity, checking the temperature of sensors 1 and 2, taking the average of the two values;
- switching on the prototype for five minutes until its operation stabilizes;
- measuring the  $T_{DB}$  and  $\varnothing$  of the air cooled by the prototype with the thermo-hygro-anemometer, near of the insufflate region and at the points specified by Figure 11;
- calculating the average for  $T_{DB}$  values measured for each point. The obtained value will be the insufflation temperature ( $T_{insf}$ );
- calculating the saturation efficiency using Eq. 1.

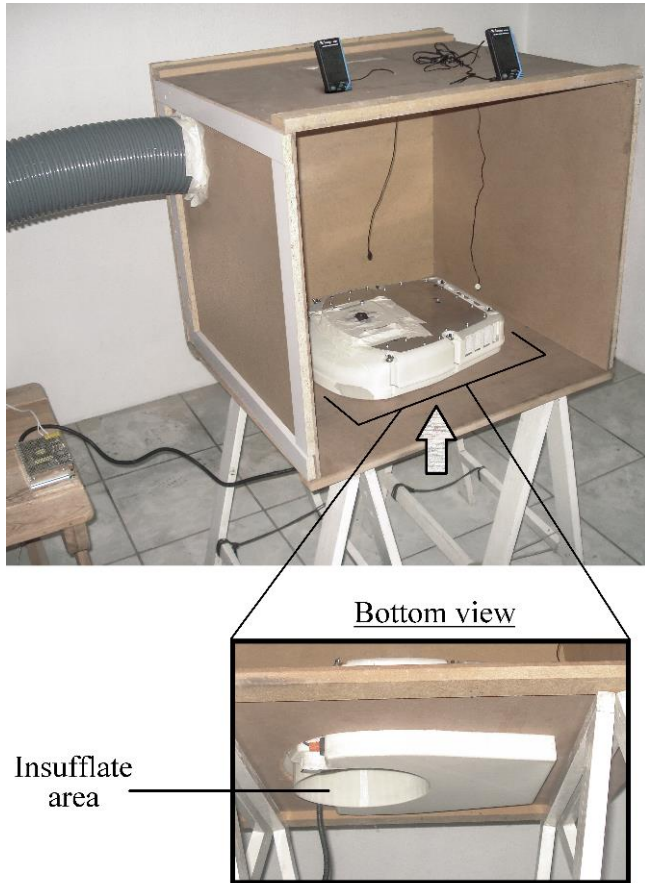

Figure 10: Assembly of the bench experiment (opened box)

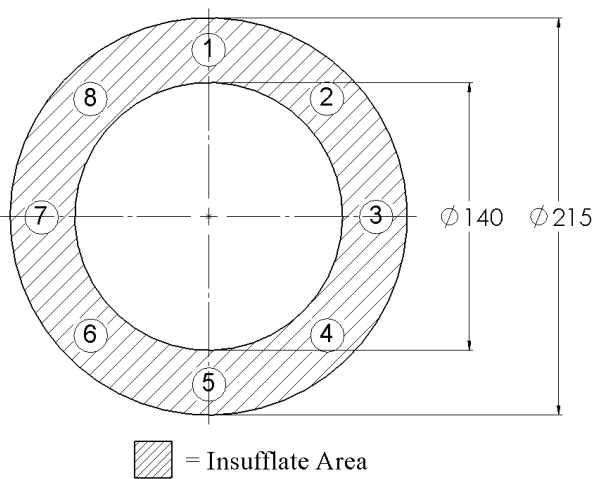

Figure 11: Measuring points in the insufflation region

To determine the prototype flow rate, the following procedures were performed:

- measuring the air velocities in the insufflation region and at the points shown in Figure 11 using a thermo-hygro-anemometer;
- calculating the average of the velocities obtained at each point to determine the average velocity of the prototype;
- determining the prototype flow rate, which is obtained through the product between the average velocity and the prototype insufflate area.

### III. RESULTS AND DISCUSSION

The results obtained experimentally had the purpose to determine the performance of the prototype and to know its technical characteristics, allowing to make the design of an evaporative cooling system for urban buses afterwards.

The Lab test room had a temperature of  $23.0 \pm 1$  °C and relative humidity of 65%, remaining in these conditions during the entire period of testing. All experiments were performed with water at room temperature.

#### PROTOTYPE SATURATION EFFICIENCY

To define prototype saturation efficiency ( $\epsilon$ ), it was measured the box internal temperature ( $T_{BOX}$ ) and the prototype insufflation temperature ( $T_{insuf}$ ), as described in the previous section. The tests were repeated for each of the three humidity conditions established.

Table 1 shows the temperatures found inside the box when the internal air reached the specified humidity level. The temperatures were obtained by sensors 1 and 2, and the mean of the two values represents the  $T_{BOX}$ .

Table 2 reports the  $T_{insuf}$  obtained for each point during the prototype test, where the last line identifies the standard deviation (SD) for the temperatures obtained.

Table 1: Temperatures [°C] inside the box

Ø [%]	Sensor 1	Sensor 2	Mean
25% (a)	36.8	37.6	<b>37.2</b>
50% (b)	30.2	31.0	<b>30.6</b>
75% (c)	31.8	32.7	<b>32.2</b>

Table 2: Temperature [°C] of the air cooled by the prototype

Point	Ø 25%	Ø 50%	Ø 75%
Point 1	26.1	25.2	29.7
Point 2	25.9	25.3	29.8
Point 3	26.2	25.0	30.0
Point 4	26.5	25.4	30.2
Point 5	26.5	25.5	30.5
Point 6	26.3	25.2	30.4
Point 7	26.4	25.4	30.1
Point 8	26.2	25.0	29.8
<b>Mean</b>	<b>26.3</b>	<b>25.3</b>	<b>30.1</b>
SD	0.21	0.19	0.29

Based on the temperature values presented in Tables 1 and 2, and with the aid of Eq. 1, the  $\epsilon$  of the prototype was determined for the three established humidity environmental conditions. The  $\epsilon$  values are presented in Table 3. The column named  $\Delta T$  represents the temperature difference between the equipment air inlet and air outlet. The column named " $\Delta T_{adb}$ " indicates the temperature reduction that would be obtained for the theoretical behavior of adiabatic saturation. Therefore,  $\Delta T_{adb}$  represents the maximum temperature reduction possible to be reached by the prototype.

Table 3: Prototype’s saturation efficiency

$\emptyset$ [%]	$T_{BOX}$ [°C]	$T_{insuf}$ [°C]	$\Delta T$ [°C]	$\Delta T_{adb}$ [°C]	$\varepsilon$ [%]
25% (a)	37.2	26.3	10.9	15.2	<b>71.7</b>
50% (b)	30.6	25.3	5.3	7.6	<b>69.7</b>
75% (c)	32.2	30.1	2.1	3.7	<b>56.8</b>

The prototype presented a saturation efficiency of approximately 70% for conditions "a" and "b", while condition "c" has lower efficiency compared with the others. This happens because the condition "c" is unfavorable for the evaporative cooling, thereby it has little capacity for temperature reduction. Because of this, the results of the "c" condition become much more sensitive and susceptible to possible variations of the test, where due to the close values, any small deviation will have a great influence on the results.

Reorganizing Eq.1 and using the obtained  $\varepsilon$  (Table 3), it is possible to estimate the temperature reduction between the air inlet and outlet ( $T_{DB,i} - T_{DB,o} = \Delta T$ ) of the prototype, for others climatic conditions. Figure 12 shows the estimated temperature reduction ( $\Delta T$ ) according to the environment temperature and its relative humidity, which represents the inlet conditions (terms  $T_{DB,i}$  and  $T_{WB,i}$  from Eq.1).

Analyzing the temperature reductions presented in Figure 12 it is observed that the prototype worked in agreement with the literature, presenting a greater temperature reduction for dry environments and a little reduction for humid environments. Table 4 presents the summary of the expected temperature reduction for the prototype, according to the relative humidity value and the ambient temperature, in operating range of 25°C to 45 °C.

**PROTOTYPE AIR FLOW RATE**

To obtain the prototype air flow rate, first the velocity of the cooled air was measured in the insufflation region with the thermo-hygro-anemometer and at the points specified by Figure 11. The velocity results are given in Table 5. The last line shows the standard deviation for the velocities obtained.

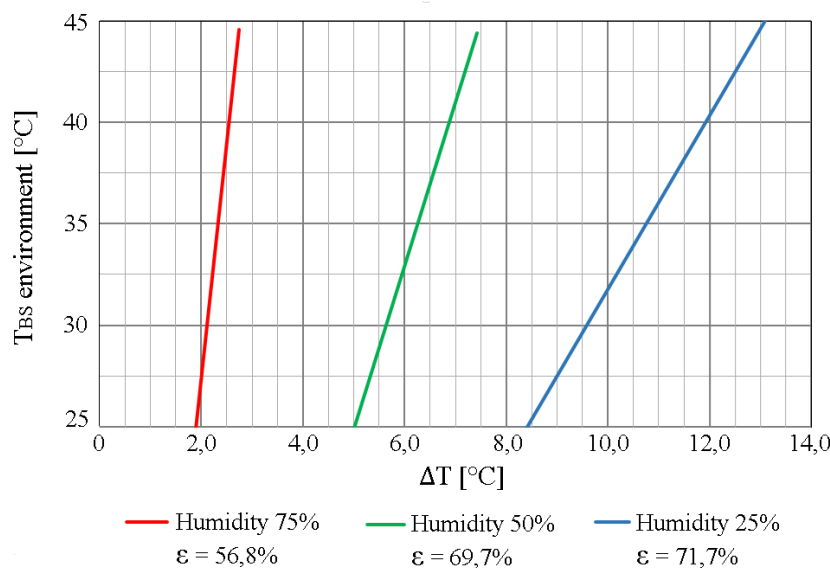

Figure 12: Estimation for the prototype temperature reduction ( $\Delta T$ )

Table 4: Estimation for the prototype temperature reduction in function of the environment humidity and temperature

$\emptyset$ [%]	Minimum Temp. reduction (25 °C)	Maximum Temp. reduction (45 °C)
25 – 50	5 °C	13 °C
50 – 75	3 °C	7.5 °C
> 75	≈ 0 °C	3 °C

Table 5: Insufflation velocity [m/s]

Point	Velocity
1	6.1
2	5.2
3	4.9
4	5.1
5	7.0
6	6.5
7	4.7
8	5.0
<b>Mean</b>	<b>5.6</b>
<b>SD</b>	<b>0.85</b>

The prototype insufflation region has an external diameter of 0.215 m, and the fan hub diameter is 0.140 m. This condition results in an insufflation area of approximately 0.021 m<sup>2</sup>. Therefore, multiplying the insufflation area by the prototype average velocity (5.6 m/s), it was obtained an air flow rate of 421.5 m<sup>3</sup>/h for the prototype.

**PROTOTYPE ENERGY CONSUMPTION**

The prototype energy consumption was determined by the values of electric current consumed by the fan and electric pump, which presented the following results:

- electric current of the fan equal to 2.3 A;
- electric current of the electro pump equal to 1.8 A.



Therefore, the total electric current consumption by the prototype was 4.1 A. The voltage of the prototype electrical components is 24 V. This voltage multiplied by the electrical current provides the energy consumption by the prototype. Thus, the prototype presented a power consumption of 98.4 W.

**Evaporative cooling system for buses**

After obtaining the operational characteristics of the prototype, it was possible to elaborate the design of the evaporative cooling system for the bus. For this study application, an urban bus model with an internal volume of approximately 55 m<sup>3</sup> was chosen.

The ANSI/ASHRAE standard 62.1 [21] specifies a minimum effective ventilation rate of 2.5 L/s to 5L/s per person for several crowded spaces. Based on it, ASHRAE [19] recommends for mass transit applications the value of 3.5 L/s of outdoor air per passenger for most transit applications. Therefore, considering the max capacity of 70 passenger (sitting and standing) for a usual city bus, then the ventilation rate must be at least 245 L/s or 882 m<sup>3</sup>/h. It was verified that three evaporative coolers are sufficient to meet this standard. In order to obtain a better internal temperature reduction, it was adopted four coolers for the bus evaporative cooling system, as illustrated at Figure 13, which shows the assemblage on the vehicle’s roof, demonstrating its arrangement and the position for the water tank, responsible for supplying the coolers.

After defined the bus cooling system, it is possible to evaluate the thermal comfort that will be provide to the passengers. The thermal comfort inside the bus was estimated through the PMV-PPD index. Indexes values were obtained from tables available on ISO 7730 [13] standard. However, to use these tables first it is necessary to know the T<sub>O</sub>, air velocity, metabolism level and clothing. The calculation of T<sub>O</sub> depends on the T<sub>DB</sub> inside the bus, which varies mainly according to the external weather and the number of passengers. The following conditions were adopted to evaluate the bus thermal comfort:

- T<sub>DB</sub> of the external weather equal to 32 °C;
- Ø of the external weather equal to 25%;

- T<sub>insur</sub> equal to 22 °C (according Figure 12);
- Passengers’ number equal to 35 people;
- solar thermal load equal to 6.0 kW [22];
- T<sub>DB</sub> inside the bus starts in equilibrium with the outside temperature (32 °C).

The variation of T<sub>DB</sub> inside the bus was determined through a thermal balance, and these calculations were realized with aid of *Matlab* software. The bus internal temperature was calculated for two cases: the first when the bus only has the air renewal required by ANSI/ASHRAE standard 62.1[21], and has no type of air conditioning system; and the second condition is for the case where the bus has the cooling system proposed by this study. The results for the temperature inside the bus are presented in Figure 14.

According Figure 14, a bus that has only the required air renewal presents an increase in its internal temperature, which is raised from 32 °C to 38.5 °C. This temperature increase happens due to the thermal loads that act on the bus, heating its interior above outdoor weather temperatures. This situation makes the thermal discomfort of passengers worse, and therefore, only air renewal is not enough to avoid the bus heating.

In turn, the proposed evaporative cooling system was able to avoid the bus heating and still had the capacity to lower the internal temperature to 28.5 °C.

After determining the T<sub>DB</sub> inside the bus, it is also needed to determine its T<sub>MR</sub>, since the combination of these two temperatures defines T<sub>O</sub>. However, this study considered that the bus interior has no important sources of radiation. Thus, it was possible to assume that T<sub>O</sub> is equal to T<sub>DB</sub> of air, as specified by the ANSI/ASHRAE Standard 55 [1]. Therefore, T<sub>O</sub> is equal to 28.5 °C.

In addition to T<sub>O</sub>, to calculate the PMV-PPD indexes it is necessary to know the air velocity that affects the passengers. The air velocity was determined through calculations established by ASHRAE [22]. Considering that the prototype insufflate region has the shape of a circular jet, and it is positioned at an average distance of 1.5 m to the passenger's head, a value of 0.6 m/s for air velocity was obtained.

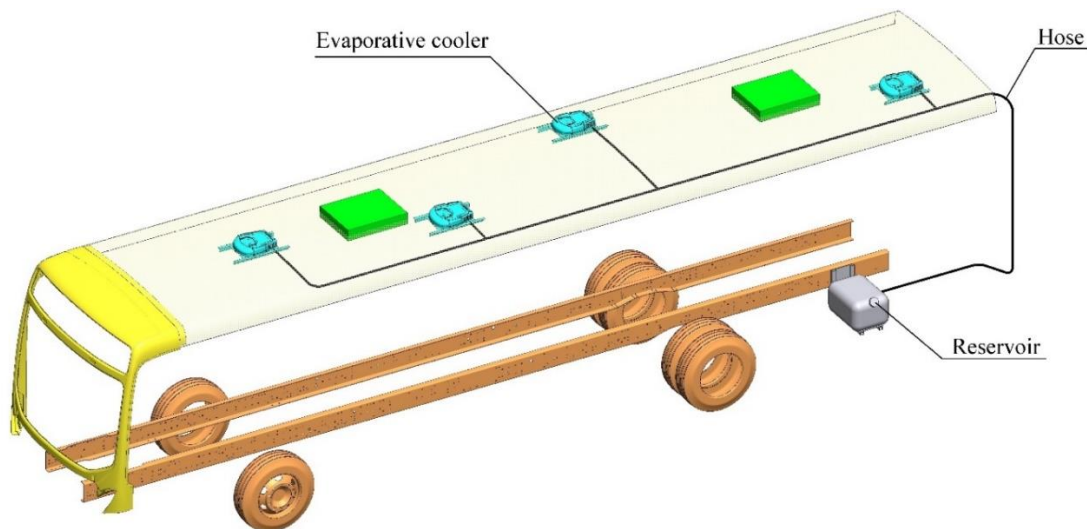

Figure 13: Evaporative cooler system for an urban bus

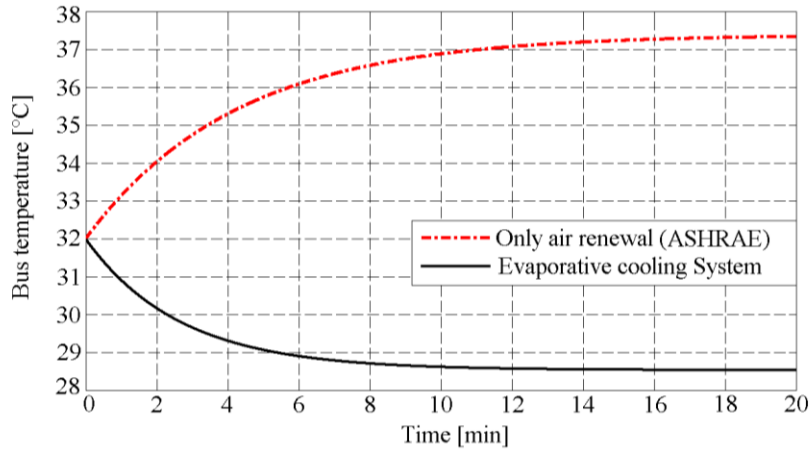

Figure 14:  $T_{DB}$  inside the bus as a function of time

The ANSI/ASHRAE Standard 55 [1] defines that a sitting and relaxed person has a metabolism of 1.0 met and a standing and relaxed person presents a metabolism of 1.2 met. Considering that an urban bus passenger may be either sitting or standing, an average metabolism of 1.1 met was adopted for bus passengers. For the clothing, a value of 0.5 clo was adopted, which corresponds to people dressed in summer clothes [13].

Therefore, considering  $T_O$  equal to 28.5 °C, air velocity of 0.6 m/s, metabolism equal to 1.1 met and clothing of 0.5 clo, a value of 0.35 was obtained for the index PMV. This result was obtained through values interpolation from tables of ISO 7730 [13].

The value of 0.35 obtained for the PMV index indicates that people will have a slight sensation of heat, but within the thermal comfort range adopted by ISO 7730 [13] and ANSI/ASHRAE Standard 55 [1], suggesting a thermal satisfaction condition for the vast majority of passengers.

Based on the PMV index value, it is possible to determine the PPD index through Figure 2, from which a value of approximately 7 is obtained for the PPD index. This means that approximately 7% of the people inside the bus will be dissatisfied with their thermal comfort.

Another way to evaluate thermal comfort is through graphic methods. The graph represented by Figure 15 was taken from standard ANSI/ASHRAE Standard 55 [1] and

presents the PMV thermal comfort zones. However, this graphic is valid only for people with met equal to 1.1 and for the case where  $T_{MR}$  is equal to  $T_{DB}$  (without radiations sources). As shown in the Figure 15, the location for the point defined by the bus conditions ( $T_O = 28.5$  °C and  $v = 0.6$  m/s) are within the thermal comfort zone for people wearing summer clothing (0,5 clo).

IV. CONCLUSION

The current air conditioning system for buses is the mechanical vapor compression (MVC) type, and presents as main disadvantages the power extraction from the vehicle engine to the compressor operation, besides the high financial cost of this type of equipment.

Therefore, as an alternative to replace the MVC system, it has been proposed new equipment that uses evaporative cooling as a working principle. This system presents a high-energy efficiency and lower financial cost. However, this type of equipment needs air renewal for a properly operation and its cooling effect depends on the environmental climatic conditions, especially concerning humidity, being not suitable for humid regions. This limitation can be eliminated or reduced by using of desiccants systems, which will dehumidify the supply air. This kind of solution was already studied for vehicles, and presented feasible results to be applied [16] and [23].

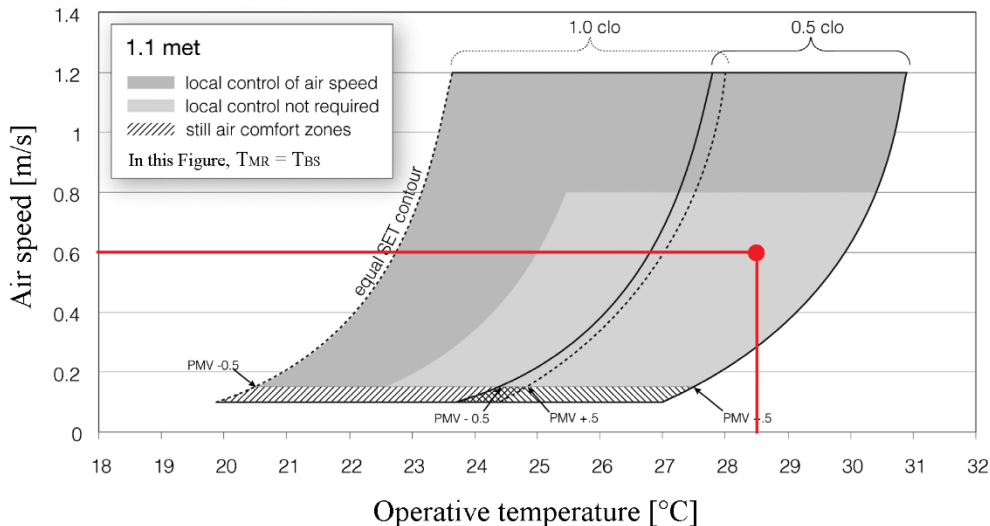

Figure 15: Location at the thermal comfort zone chart for the point defined by the bus conditions

After conclusion of the project phase, a prototype was built and tested experimentally to obtain its technical operation characteristics. The prototype presented a saturation efficiency of approximately 70% and air flow rate of 421.5 m<sup>3</sup>/h, with a power consumption of 98.4 W.

Through the analysis of the experimental results, it was verified that for environments with relative humidity above 80%, the cooling effect is almost null. However, for values of relative humidity below 50%, the equipment presented a reduction of at least 5 °C, reaching 13 °C when the humidity is less than 25%, enabling its use in dry or moderate humidity environments.

After determinate the prototype technical characteristics, it was possible to design the evaporative cooling system for the bus. Four coolers were considered to the proposed cooling system. This amount of equipment is above that specified by the ANSI/ASHRAE standard 62.1 [21] for air renewal. However, this condition was adopted in order to obtain a better air distribution inside the vehicle and reach better results for the internal temperature reduction.

The performance of the proposed evaporative cooler system was evaluated for a condition where the bus has a total of 35 passengers, with an external temperature of 32 °C and a relative humidity of 25%. For these conditions, the system presented a value of 0.35 for the PMV index, indicating the thermal comfort of the passengers.

The four coolers installed on a bus presented the total power consumption of approximately 0.4 kW. Considering that a MVC system average consumption is 8.0 kW, it means that the proposed evaporative cooler system was able to provide thermal comfort to the passengers, consuming just 5% of the energy that would be consumed by the MVC system for the established weather conditions.

The main advantage of the proposed evaporative cooler system, in relation to MVC systems, is its cost-benefit, because it has a lower financial value, operates with low energy consumption and does not use power extracted from the vehicle engine, operating without extra fuel consumption. When applied in favorable conditions (low humidity), the evaporative cooling system proved to be a viable solution to replace the MVC systems for bus air conditioning application.

Due to the low power consumption presented by the prototype, it is possible to consider an increasing in the number of coolers that was used in the proposed evaporative cooler system. This will improve the thermal comfort levels inside the bus, ensuring the system is still able to provide thermal comfort to passengers even when under less favorable conditions, which is the case of regions with moderate relative humidity.

Following this study, the next step is evaluating the real efficiency of the proposed system applying it in a urban bus. In addition, it is desired to propose a new geometry for the grilles or to develop other solutions to improve contact between air and water, aiming to increase the saturation efficiency of 70% obtained in this study.

## V. BIBLIOGRAPHY

- [1] ANSI/ASHRAE *Standard 55-2010*: Thermal environmental conditions for human occupancy. Atlanta, EUA: ASHRAE Inc., 2010.
- [2] S.K. Wang. *Handbook of air conditioning and refrigeration*. 2. ed. New York: McGraw-Hill, 2001.
- [3] M.F. Sukri et al. "Achieving a better energy-efficient automotive air-conditioning system: a review of potential technologies and strategies for vapor compression refrigeration cycle". *Energy Efficiency*, Volume 8, Issue 6, pp 1201–1229, 2015.
- [4] S. Datta et al. "Design and operating characteristics of evaporative cooling systems". *International Journal of Refrigeration*, Volume 10, Issue 4, pp 205-208, 1987.
- [5] J.R. Camargo; C.D. Ebinuma; S. Cardoso. "Three methods to evaluate the use of evaporative cooling for human thermal comfort". *Thermal Engineering*, Volume 5, Issue 2, pp 09-15, 2006.
- [6] H. Lotfizadeh; M. Layeghi. "Design and performance analysis of a small solar evaporative cooler". *Energy Efficiency*, Volume 7, Issue 1, pp 55–64, 2014.
- [7] Y.A. Çengel; A.J. Ghajar, *Heat and mass transfer: Fundamentals & Applications*. 5 ed. New York: McGraw-Hill, 2015.
- [8] J. R. Watt; W. K. Brown, *Evaporative Air Conditioning Handbook*. 3. ed. Lilburn: The Fairmont Press, 1997.
- [9] G.J. Bom et al. *Evaporative air-conditioning: applications for environmentally friendly cooling*. Washington, DC: The World Bank, 1999.
- [10] American Society of Heating, Refrigerating and Air-Conditioning Engineers. *ASHRAE handbook: HVAC Systems and Equipment*. Atlanta: ASHRAE, 2008.
- [11] Y. Epstein; D.S. Moran. "Thermal Comfort and the Heat Stress Indices". *Industrial Health*, Volume 44, pp 388–398, 2006.
- [12] K.C. Parsons. *Human Thermal Environments: The effects of hot, moderate, and cold environments on human health, comfort and performance*. 2. ed. New York: Taylor & Francis Group, 2003.
- [13] International Standards Organization. "ISO 7730: Ergonomics of the thermal environment: Analytical determination and interpretation of thermal comfort using calculation of the PMV and PPD indices and local thermal comfort criteria". Geneva:ISO, 2005.
- [14] J.R. Watt. *Evaporative air conditioning handbook*. 2.ed. London: Chapman and Hall, 1986.
- [15] S. Delfani et al. "Energy saving potential of an indirect evaporative cooler as a pre-cooling unit for mechanical cooling systems in Iran", *Energy and Buildings*, Volume 42, Issue 11, pp 2169-2176, 2010.
- [16] A. Alahmer. "Thermal analysis of a direct evaporative cooling system enhancement with desiccant dehumidification for vehicular air conditioning". *Applied Thermal Engineering*, Volume 98, pp 1273-1285, 2016.
- [17] J.S. Thakur; A. Bergaley. "Performance Evaluation of Evaporative Air Conditioning System for Truck Cabins in Indian Environmental Conditions". *International Journal of Innovative Research in Science, Engineering and Technology*, Volume 4, Issue 8, pp 7851-7856, 2015.
- [18] S.K. Kushwaha; A.C. Tiwari. "Evaporative cooling comfort in agricultural tractor cabin". *Journal of the Brazilian Society of Mechanical Sciences and Engineering*, Volume 38, Issue 3, pp 965-976., 2016.
- [19] American Society of Heating, Refrigerating and Air-Conditioning Engineers. *ASHRAE handbook: HVAC Applications*. Atlanta: ASHRAE, 2011.
- [20] GEA, Bock FK Compressors for mobile applications [https://vap.gea.com/Documentation/Data/DocumentationFiles/09689\\_Mobile%20Applications.pdf](https://vap.gea.com/Documentation/Data/DocumentationFiles/09689_Mobile%20Applications.pdf). Accessed 29 October 2017.
- [21] ANSI/ASHRAE *Standard 62.1-2007*: Ventilation for Acceptable Indoor Air Quality. Atlanta, EUA: ASHRAE Inc., 2007.
- [22] American Society of Heating, Refrigerating and Air-Conditioning Engineers. *ASHRAE handbook: Fundamentals*. Atlanta: ASHRAE, 2009.
- [23] A.A. Pesaran; Y.O. Parent; D. Bharathan. "Non-CFC Air Conditioning for Transit Buses." *SAE transactions* Vol. 101. pp. 750-759, 1992.