

# Design, fabrication, and assessment of a hydraulic arm with quick coupling system for tractors

Rubens Meneguzzi\*, José Antonio Portella†

## Abstract

Food production processes have required increasing productivity, efficiency, and agility in mechanized agricultural operations. This study aimed to design and size a hydraulic arm with the quick coupling of implements for the three-point system of category II tractors. For the project design, a product development methodology was used until obtaining the final variant of the tractor-implement coupling system. The draft and its detailing were developed and, in order to validate the concept, the mechanism prototype was fabricated to test its operation on the field. The accelerations working on the three-point hitch system were measured to optimize the design. The data collected served as a database for a structural analysis of the set by the finite element method. The structural analysis simulations showed Von Mises values between 70 and 140 MPa and displacement values between 0.3 and 1.2 mm. These analyses were performed with the combination of the weight force of the implement and the acting accelerations, which presented results for system validation. It was verified that overloads occur in two regions: the lateral stabilizer bars support and the hook. Under extreme conditions, the stabilizer bars extrapolated the yield value of the material, and failures and plastic deformations may occur in these regions. The prototype test proved the agility and practicality of the system.

## Keywords

Agricultural mechanization, Assembled implements, Three-point hitch systems

## I. INTRODUCTION

Considering planting and soil-tillage intervals are increasingly shorter, coupling and adjusting several implements is very time-consuming because it is a manual process. The stabilizer bars of hydraulic arms, which are usually attached with pins, often break and cause damages and delays to producers.

The three-point hitch system of the agricultural tractor is a mechanism used to couple agricultural implements, but there are only a few studies performed so far that use optimization models for such process. It is vital to develop studies on the system, and accurate surveys of the models in the market and their constructive availability are required to optimize the design of a quick coupling system between tractors and implements. Besides developing a new three-point hitch concept for tractors, it is also required to determine the efforts working in the hitch system, which generates technical information that may be applied in other projects. This new concept of tractor-implement quick coupling system will help in operational safety and reducing labor and coupling times.

International literature does not describe similar developments. The search for patents allowed us to visualize the state of the art. The engineered design allowed a significant improvement in coupling time and safety.

## II. MATERIAL AND METHODS

An experimental procedure was performed to measure the acting accelerations in a three-point hitch system to determine the working efforts and assess the functioning of the quick coupling system between tractor and implement (Fig. 1). The data collected will serve as a database in the simulations.

The experiment was performed in a property located at Linha Primeira Aparecida, city of Vanini, 90 km from the city of Passo Fundo, Rio Grande do Sul, Brazil. The tractor used in this test is from the brand New Holland, model TL 75E, year 2009, 75 HP, 4X2 front wheel drive (FWD) traction. It has an electro-hydraulic drive, power take-off (PTO), lifting capacity of 4000 kg, and tank capacity of 110 liters of diesel oil, whereas the tank, radiator, and the lubricating and hydraulic fluids reservoir were full. This tractor weighs 3260 kg without ballast and 3880 kg with ballast, therefore according to the NBR-ISO 730 standard [3], it belongs to category II of tractors.



Fig. 1: New quick coupling system between the tractor and the implement.

\*Meneguzzi Máquinas & Equipamentos – Universidade de Passo Fundo (UPF) Parque, RS, Brasil; †Universidade de Passo Fundo (UPF), RS, Brasil. E-mails: rubens.meneguzzi@meneguzzi brasil.com.br, japortella13@gmail.com

The implements chosen for analyzing force were a subsoiler and a sprayer, which were used for measuring the acceleration produced by the tractor-implement set. Such implements require higher forces in the three-point set of the tractor.

The model of the subsoiler selected is equipment with 1.60 meters of width and five shanks. The spacing between rows is 345 mm and the equipment weighs 440 kg, requiring a power of 60 HP for traction. Considering several studies are determining the efforts in subsoiler shanks, the information presented in the study by Leonardo Furini [4] was used, which determined vertical and horizontal forces working on a subsoiler shank. The test was performed at two working depths and two speeds to determine the maximum vertical and horizontal forces.

For maximum vertical force, Leonardo Furini [4] found 165.89 kgf for each shank. A calculation software will determine the static analysis of the set with the values of such forces added by the acceleration values.

#### Acceleration measurement

For collecting acceleration signs, two piezoelectric accelerometers were installed in the lower hydraulic arms of the tractor and in the sprayer. These accelerometers are type 8-32 VDC, model 2460-010 XY, from the brand SILICON DESIGNS. Fig. 2 shows both accelerometers: Accelerometer A was called "1" and measured the input data, and accelerometer B was called "2" and measured the output data. Accelerometer A was attached to the hydraulic arm of the tractor, and accelerometer B was attached to the sprayer structure.



Fig. 2: Accelerometer A located in the hydraulic arm and accelerometer B located in the implement.

After installing in the tractor and the implement, the accelerometers were assessed and then three routes were performed for data acquisition. The data measured in the accelerometers were sent to software that stored these data for posterior analysis. Fig. 3 presents a tractor-sprayer set, the ground where the tests were performed, and the data acquisition equipment.



Fig. 3: Test performed for measuring the acceleration in a three-point system.

The data acquisition equipment measured acceleration in three directions (X, Y, and Z) for each accelerometer and in each route. Directions X, Y, and Z are longitudinal, transverse, and vertical, respectively. The positive X value is from the sprayer toward the tractor (direction ahead of the tractor), the positive Y value is from the center out of the tractor, and the positive Z value is from the vertical direction of the ground upward.

The data acquired in the measurement were analyzed with the Catman software from the HBM manufacturer. Initially, these data received a statistical treatment to verify whether the values were normal, and later the maximum, minimum, mean, and standard deviation values were analyzed for each data collection. The importance of collecting the acting accelerations is because they determine the effort performed in the three-point hitch system through  $mass \times acceleration$ , in which the force is obtained.

#### Structural analysis by the finite element method

As described by Avelino Alves Filho [1], the static analysis may, however, include static inertial loads such as gravitational acceleration or rotational speed. The static analysis may be used to determine displacements, stresses, specific deformations, and forces in structures or components caused by loads that do not induce significant effects of inertia or damping. Therefore, two types of loading applied to this analysis are concluded: forces resulting from agricultural implements and forces resulting from the acceleration of the operating tractor-implement set.

The simulation used two materials, as described by Michael Ashby [2], to assess the system:

**1<sup>st</sup>. A36 structural steel alloy:** presents the characteristics of 7.85 mg/m<sup>3</sup>, tensile yield strength of 210 MPa, Poisson coefficient of 0.3, and elasticity modulus of 200 GPa. The cost is relatively low when compared to its large agricultural application.

**2<sup>nd</sup>. LN 38 steel:** hot-rolled steel, yield strength of 380 MPa, Poisson coefficient of 0.3, elasticity modulus of 200 GPa, and ultimate tensile strength of 600 MPa. It is indicated for the fabrication of agricultural wheels and equipment.

Fig. 4 shows the pre-processing of the analysis, which was set to simulate the efforts of the sprayer and the accelerations working together. The type of mesh applied is composed of linear tetrahedral elements of four knots in the solid pieces of the bars and axis of the tractor, beam elements to represent the actuators, that is, the lateral stabilizer bars and the third point of the tractor.

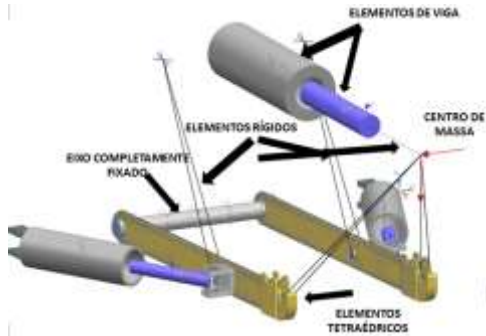

Fig. 4: Pre-processing of the analysis by the finite element method (FEM). Legend: *Elementos de viga*: Beam elements; *Centro de massa*: Mass center; *Elementos tetraédricos*: Tetrahedral elements; *Eixo completamente fixado*: Completely attached axis; *Elementos rígidos*: Rigid elements.

The model was discretized with the following elements: Stabilizer bars - CTETRA4, medium size of 10 mm; Axis - CHEXA8, size of 8 mm; Welded supports - CTETRA4, size of 10 mm; Hook plates - CHEXA8, size of 6 mm; and Hook - CHEXA8, size of 6 mm. A total of 42522 knots and 83392 elements were produced. Rigid elements were used to represent the connections. Moreover, glue contacts were used between welded pieces, and sliding contacts were used between moving pieces. An element of concentrated mass was used at the center of gravity of the sprayer.

In the sequence of the static analysis, a pre-processing was set for the second phase of the analyses, in which the forces of a subsoiler working in the system were used. In this case, the aim was to analyze accurately the catch of the system, which function is to maintain the implement attached to the three-point hitch system. The subsoiler causes a tractive effort in the hook and shear strength in the catch, as presented in the arrow directions of Fig. 5.

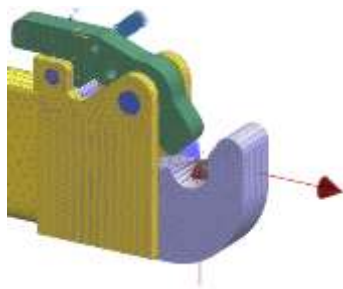

Fig. 5: Direction of the acting forces through a subsoiler.

The system restrictions remained the same, but the acting forces changed. In this phase, the acting forces were obtained from the study by Leonardo Furini [4], which determined the horizontal and vertical forces working individually in each subsoiler shank. The analysis was characterized in the following elements: Hook plates - CHEXA8, size of 2 mm; Hook - CHEXA8, size of 4 mm; Catch - CHEXA8, size of 2 mm; and Pins - CTETRA4, sizes of 5 mm and 2 mm. This resulted in 126199 knots and 154409 elements.

This second model has two rigid connections, considering the first connection contains the vertical loading, which forces the catch to break, and the second connection contains the

horizontal loading in " -X", which forces the hook to break and causes tractive efforts.

### III. RESULTS

Graphs were produced for all situations from the data acquisition, meaning an acceleration graph in the three positions for the three tests with both accelerometers, resulting in 18 graphs. The graph presented in Fig. 6 mentions the acceleration measured in accelerometer 1, route 1, and direction X. In the graph, the X-axis presents the values of time in seconds and the Y-axis shows the acceleration value measured in gravity (g).

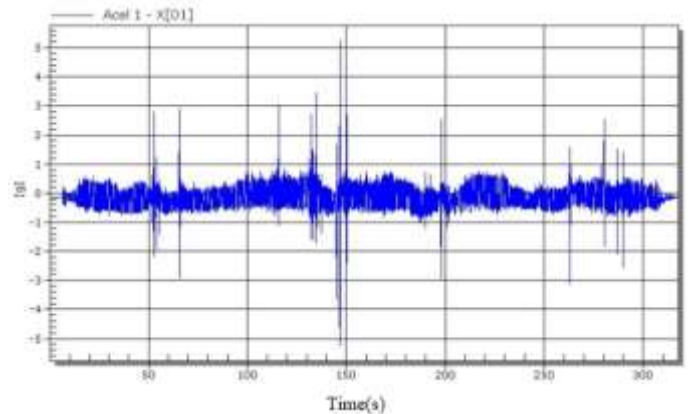

Fig. 6: Acceleration measured in route 1, accelerometer 1, and direction X.

For performing the work sequence, the data from test 1 were summarized and presented in Tab. 1.

Tab. 1: Acceleration values measured in the tests.

Accelerometer 1		Accelerometer 2	
<b>TEST 1 (X)</b>		<b>TEST 1 (X)</b>	
Number of data	190682	Number of data	190682
Mean (g)	-0.1177 g	Mean (g)	-0.1865 g
Maximum (g)	5.255 g	Maximum (g)	5.923 g
Minimum (g)	-5.235 g	Minimum (g)	-6.020 g
<b>TEST 1 (Y)</b>		<b>TEST 1 (Y)</b>	
Number of data	190682	Number of data	190682
Mean (g)	0.04860 g	Mean (g)	0.02936 g
Maximum (g)	12.12 g	Maximum (g)	2.004 g
Minimum (g)	-8.453 g	Minimum (g)	-1.277 g
<b>TEST 1 (Z)</b>		<b>TEST 1 (Z)</b>	
Number of data	190682	Number of data	190682
Mean (g)	0.9469 g	Mean (g)	0.9453 g
Maximum (g)	5.050 g	Maximum (g)	2.434 g
Minimum (g)	-1.999 g	Minimum (g)	-2.266 g

High acceleration values were observed, such as in test 1, accelerometer 1, and direction Y with the value of 12.12 g, due to the severe test conditions to which the tractor was subjected when it reached constant speed and passed over a hole or ditch ahead, thus producing an acceleration peak. Test 2, accelerometer 1, and direction Y showed the maximum value of 10.52 g, and there were stones in the path, which caused acceleration peaks when passing over them. However, the mean values found were satisfactory, considering the use as a database for the static analysis of the system.

After the pre-processing of the numerical model, the first static analysis of the system was performed, consisting of the combination of the weight force of the sprayer (800 kg) with the combination of accelerations measured and the A36 material. In the first analysis, the data collected in circuit 2 were used with the data from accelerometer 1, meaning values measured in the arm of the agricultural tractor that presented higher values. Fig. 7 shows the stress values considering all positive values. The highest stress effect is on the stabilizer bar support region, with values of 120 MPa, and the hook region of the quick coupling system, with values of 130 MPa, as observed in Fig. 8.

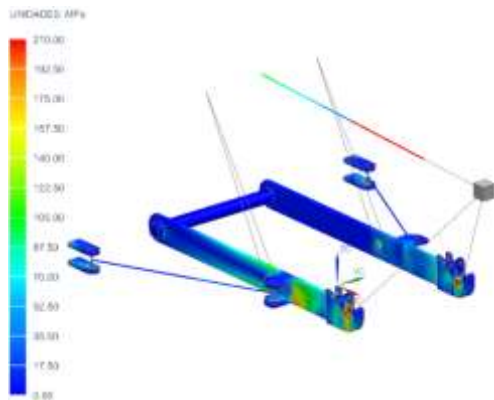

Fig. 7: Analysis of stress values. Legend: *Unidades MPa: Units MPa.*

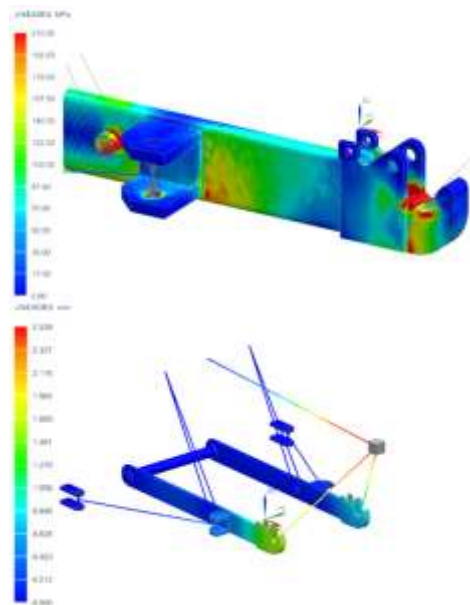

Fig. 8: Detail of stress in the hydraulic arm. Legend: *Unidades MPa: Units MPa.*

For displacement values, the system presented maximum values close to 1.2 mm in the quick coupling region (Fig. 8).

The analyses were performed by combining the weight force of the implement and the acting accelerations, presenting satisfactory results. In practice, the region with the highest fracture of the three-point lifting system is the bar support, therefore the present simulation behaved similarly to the actual functioning of the system. This showed two regions that should be given special attention: the lateral stabilizer bar support and the hook. Some parts of the stabilizer bars extrapolate the yield value of the material, which occurred because high acceleration values were used, meaning that peaks of stress were analyzed instead of mean values. Failures and plastic deformations may occur in these regions. It is also noted that the stress gradients of the graphs were limited to a maximum of 210 MPa, which represents the tensile yield strength of the material. Therefore, it is possible to identify specific regions in red, which may represent stress accumulation and potential failures or permanent deformations.

After the analyses with the A36 structural steel, the material was replaced with the LN 38 steel to perform a comparative analysis in the regions presenting higher stress concentration in the first simulations. The LN 38 steel has a yield strength of 380 MPa, the tensile strength of 600 MPa, Poisson coefficient of 0.3, and elasticity modulus of 200 GPa.

The linear analysis was used. Thus, there is a relationship to be respected between stress and deformation:  $Stress = Elasticity\ modulus \times Deformation$ . The linear analyses depend on the elasticity modulus and the Poisson coefficient to form the stiffness matrices. These data present low variations for the different types of steel. Fig. 9 shows the displacement of the system with the new material simulated.

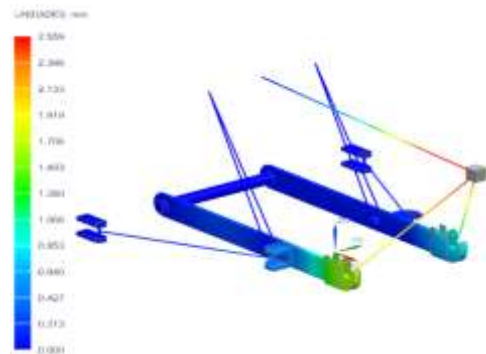

Fig. 9: Displacement of the LN 38 steel. Legend: *Unidades MPa: Units MPa.*

Replacing the material means that the safety coefficient increases because the yield strength surpasses 210 MPa to 380 MPa. Fig. 10 presents the Von Mises stress values.

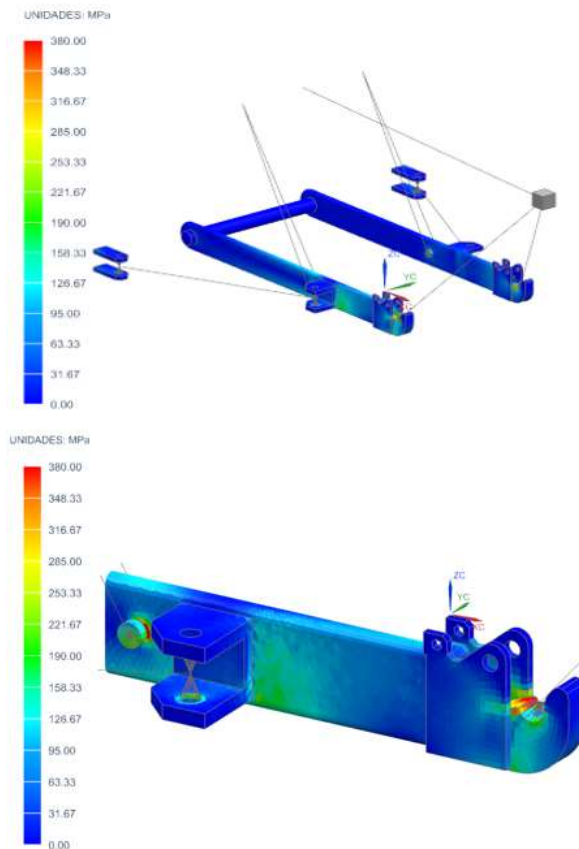

Fig. 10: Von Mises stress for the LN 38 steel. Legend: *Unidades MPa*: Units MPa.

The images produced show that when this limit is increased, both the bar and the hook can resist better to the efforts. Lastly, it was found that the hook and bar support regions started to present improved support to the loads applied to the three-point hitch system.

#### IV. CONCLUSIONS

The results obtained in this study allow concluding that the product development method helped to predict situations and problems that would only be identified in prototype fabrication and testing, minimizing costs, and reaching the best functioning concept of the system for next project advancement. The method also guides the organization of the product, considering that if the project becomes commercial, it has an organized structure to meet the demands.

Prototype fabrication allowed analyzing the functioning of the system and testing the new three-point system with quick coupling allowed improving the process. The tests did not require additional labor, confirming the optimization of the process. The reduction of time is one of the main characteristics of this new system, making it agile and contributing to significant fuel savings in the coupling process alone.

In the three circuits in which accelerations were measured, standard working conditions were simulated and the accelerations collected may be used as a database for further analyses. The accelerations affected the efforts of implements in the three-point hitch system directly. Identifying accelerations in severe conditions allow obtaining reliable data of the forces working in the system.

The numerical analysis of the three-point hitch system of the agricultural tractor made it possible to conclude that the system corresponded accurately to the working efforts. The model analyses presented stress concentration exactly at typical fracture points of the three-point hydraulic lifting system. The replacement with a new material allowed improving system strength.

#### V. REFERENCES

- [1] Avelino Alves Filho, "Elementos Finitos: a base da tecnologia CAE – Análise Dinâmica", Érica: São Paulo, 2ª ed., 2013.
- [2] Michael Ashby, "Seleção de materiais no projeto mecânico", Elsevier: Rio de Janeiro, 4ª ed., 2012.
- [3] NBR-ISO 730, Associação Brasileira de Normas Técnicas, "Tratores agrícolas de rodas: engate traseiro de três pontos - Categorias 1 N, 1, 2 N, 2, 3 N, 3, 4 N e 4", Rio de Janeiro, p. 16. 2011.
- [4] Leonardo Furini, "Desempenho operacional de hastes e ponteiras na descompactação de solo", Dissertação (Mestrado) – Programa de Pós-Graduação em Projeto e Processos de Fabricação, Universidade de Passo Fundo, Passo Fundo, 105 f., 2018.



**Rubens Meneguzzi**, Graduado em Engenharia Mecânica (2017) pela Universidade de Passo Fundo, Pós graduado em Projeto e Processos de Fabricação (PPGPPF) pela Universidade de Passo Fundo, Gerente Comercial da STARTUP Meneguzzi Máquinas & Equipamentos. Atualmente é Docente no Centro de Ensino Superior Rio Grandense (CESURG - MARAU) e coordenador do curso de Engenharia Mecânica.



**José Antonio Portella**, Graduado pela Faculdade de Engenharia e Arquitetura da Universidade de Passo Fundo (1978), Mestre em Engenharia Agrícola pela Universidade Estadual de Campinas (1983) e Doutor em Engenharia Mecânica pela Universidade Estadual de Campinas (1991). Professor titular aposentado da Universidade de Passo Fundo e Professor do Programa de Mestrado Profissional da Faculdade de Engenharia e Arquitetura da UPF.