

# Influence of sulfide on the evaluation of methane production through the degradation of sugarcane vinasse

Vanessa V. Peruzzo\*, Felipe H. Sachett\*, Ana Paula R. Torres†, M. P. de Souza† and Lademir L. Beal\*

## Abstract

Anaerobic digestion is a widely used effluent and organic waste treatment practice, in which it is possible to minimize and control environmental problems, associating the reduction of environmental impacts with energy recovery. Low methane production and process instability are often found in anaerobic digestion reactors, preventing this technique from being widely applied. Inhibitory substances, such as sulfides resulting from sulfate conversion by the sulfur reducing bacteria, are one of the causes of inhibition or malfunctioning of anaerobic digesters if they are present in the effluent to be treated. The objective of this work is to evaluate the effect of sulfide at two different values of pH (7.0 and 7.5) using sulfide concentrations of 0 to 1000 mg S<sup>2-</sup>L<sup>-1</sup>. All the tests were performed in batches and performed at mesophilic conditions. For the concentrations of 50 mg S<sup>2-</sup>L<sup>-1</sup> and 1000 mg S<sup>2-</sup>L<sup>-1</sup>, the inhibitions of the methanogenic activity at pH 7.0 were in the order of 38.5% to 59.8% and at pH 7.5 in the order of 67% to 94%, respectively. Concerning the test at pH 7.0, the removal of COD in the experiment without addition of any concentration of S<sup>2-</sup> was 93.3%, and it reached a 49.14% COD removal at concentrations of 1000 mg S<sup>2-</sup>L<sup>-1</sup>. At pH 7.5 under the same conditions, the COD removals were respectively 80.7% and 9.6%. The concentrations of 50, 75 and 100 mg S<sup>2-</sup>L<sup>-1</sup> of S<sup>2-</sup> initially tested at the two aforementioned pH values promoted the greatest increase in the reduction of SMA. When the experiments were carried out at pH 7.0 the reductions were 37.96%, 41.70%, and 46.06% respectively for the same concentrations. At pH 7.5 the reductions represented 67.01%, 82.47% and 81.81%.

## Keywords

Anaerobic digestion; Inhibition of methanogenic activity; Sulfides; Vinasse

## I. INTRODUCTION

Anaerobic digestion involves the degradation and stabilization of biological materials under oxygen-free conditions and with negative redox potential, leading to the formation of biogas (a mixture mainly formed by methane and carbon dioxide) from a renewable energy source. Thus, the digestion is a viable option for the processing of liquid effluents, such as sugarcane vinasse. This effluent comes from the manufacturing process of ethanol and with a very significant generation. In 2015, the production of 31.8 million cubic meters of ethanol [1] was achieved, which represents an average of 429.3 million cubic meters of vinasse produced.

The current destination of this liquid effluent is for the irrigation of the agricultural soil where the sugarcane is cultivated. This practice contributes to the soil and water resources contamination, due to the high organic load (COD) and acid pH present in the vinasse, as well as the frequency of application. The treatment of vinasse through anaerobic processes allows the recovery of energy with the methane production, without interfering with its quality as biofertilizers [2].

Besides being a liquid substrate with a high COD, the vinasse is also rich in sulfate, due to the sulfation process used in the production of raw sugar and the addition of sulfuric acid to avoid bacterial contamination during

alcoholic fermentation [3]. Due to the process of sulfate reduction under anaerobic conditions, high levels of hydrogen sulfide are obtained [4].

At high concentrations sulfide interferes with the viability of the vinasse treatment processes, inhibiting the activity of the methanogenic archaea responsible for the conversion of organic matter to biogas. For Colleran, Finnegan and Lens [5] in anaerobic conditions, the sulfur-reducing bacteria (SRB) produce sulfide through its reductive dissimilation metabolism of the S<sup>6+</sup> ion. In addition to the inhibitory effect of sulfide and non-ionized hydrogen sulfide [6,7], the presence of sulfate in high concentrations causes a variation in the anaerobic digestion metabolic routine, since SRB will compete for the same substrate with the anaerobic bacteria involved in the methanogenesis. Substrates include monomeric compounds such as sugar and amino acids. There is also competition with acetogenic bacteria concerning intermediate fermentation products, such as propionate, butyrate, and ethanol, with the homoacetogenic bacteria concerning H<sub>2</sub> and with the methanogenic bacteria regarding the direct substrates of methanogenesis, H<sub>2</sub>, and acetate.

Table 1 compares information from different authors regarding the inhibitory concentrations of sulfide found in anaerobic digestion.

The sulfate concentrations in sugarcane vinasse range

\*Laboratory of Environmental Technologies - University of Caxias do Sul, Rio Grande do Sul, BR; †Research and Development Center Leopoldo Américo Miguez de Mello, Petrobras, BR.  
E-mails: vanessa.eng@hotmail.com; fhsachett@ucs.br; aptorres@petrobras.com.br; mpsouza@petrobras.com.br; llbeal@ucs.br

from 1300 to 5000 mg SO<sub>4</sub><sup>2-</sup>·L<sup>-1</sup> [15,7,16,17,18]. The sulfur sulfide conversion in anaerobic digestion can be obtained through the process of global reduction of sulfur, represented

by Equation 1 [19], where CH<sub>2</sub>O represents an organic compound.



Tab. 1: Sulfide inhibitory concentrations by several authors

Inhibitory sulfide concentration (mg S <sup>2-</sup> ·L <sup>-1</sup> )	Author's considerations	Reference
290	With the exception of sulfates, all other sulfur compounds inhibit anaerobic digestion at this concentration.	[8]
50 to 100 (tolerable with little or no acclimatization) up to 200 (tolerable with acclimatization) over 200 (quite toxic)	The concentrations analyzed are related to soluble sulfides. As for the insoluble sulfides, they did not exert toxic effects in the anaerobic digestion.	[9]
100 to 800	Concentrations analyzed from soluble sulfide or from approximately 50 to 400 mg·L <sup>-1</sup> of undissociated H <sub>2</sub> S.	[10]
50	Concentration found which already causes significant inhibition.	[11]
340	The concentration that completely inhibited methane production.	[12]
100 to 150	Concentrations leading to severe inhibition at a pH of 6.8.	[13]
250	The concentration of hydrogen sulfide leading to a 50% inhibition in the range of pH from 6.4 to 7.2.	[14]

In anaerobic digestion, the pH is also a parameter to be considered. For Budiyo, Syaichurrozi and Sumardiono [20], changes in pH influence the activity of the bacteria in the fermentation process. Sulfide Toxicity appears to be correlated with the concentration of free hydrogen sulfide in the range of pH from 6.4 to 7.2 and total inhibition at concentrations higher than pH 7.2 [6,21]. Visser, Nozhevnikova and Lettinga [22] studied the inhibition of methanogenic activity by sulfides in thermophilic processes and found better results with pH around 7. At pH above 7.25 and 7.5, the methanogenic activity was relatively low.

Considering that vinasse presents sulfate in its composition and knowing the importance of pH in the process, this research aims to show which sulfide concentrations and pH value are more likely to cause inhibitions or failures in the digester. Thus, batch reactors operating under mesophilic conditions and at two different pH conditions, 7.0 and 7.5, were used to determine the existence of methanogenic activity inhibitions by sulfides. Concentrations of 0 to 1000 mg S<sup>2-</sup>·L<sup>-1</sup> were evaluated.

## II. MATERIALS AND METHODS

### A. Equipment

The tests were conducted using a 7.5 L total volume reactor of the brand New Brunswick BioFlo/ CelliGen 115 (Figure 1). The reactor was operated at a useful volume of 5 L and stirred using a six flat blades system. The reactor contains a set with four equidistant baffles, each 20 mm wide.

The equipment control unit allowed the determination and maintenance of the parameters, such as pH, temperature and redox potential (Eh).

To quantify the gas produced, reservoirs with a capacity from 8 to 10 L were used. The liquid displacement produced by the methane was quantified by 1,000 mL beakers, located below the reservoirs.

### B. Characteristics of the inoculum

An anaerobic granular sludge with good methane production capacity (high specific methanogenic activity - SMA) obtained from a UASB (Upflow anaerobic sludge blanket) effluent treatment reactor from a food and beverage

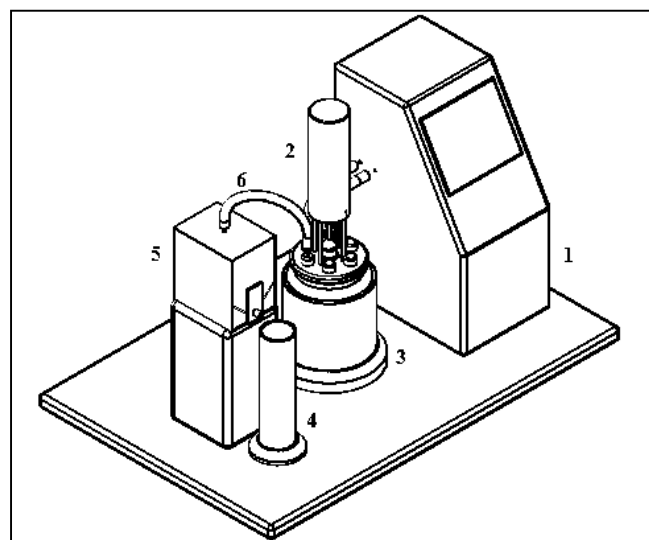

Fig. 1: Experimental unit used to perform the tests consisting of a fermenter, a control and command panel, and an alkaline water reservoir (pH 12). (1) data input and output control panel; (2) mechanical stirrer; (3) batch fermenter; (4) graduated cylinder for the quantification of the gas produced volume; (5) water reservoir; (6) gas passage hose.

industry located in the city of Esteio/RS was used as inoculum in the fermenter. A TVS (Total volatile solids) concentration of 90,300 mg·L<sup>-1</sup> was obtained for the sludge. To obtain a TVS concentration of 3,000 mg·L<sup>-1</sup>, a slurry volume of 166.11 mL was added to all the experiments.

### C. Substrate characteristics

A solution of sodium acetate trihydrate was used as the substrate in all the experiments so that the COD would be

2,000 mg O<sub>2</sub>·L<sup>-1</sup> in all the experiments. A nutrient solution containing 0.5 g·L<sup>-1</sup> of ammonium chloride, 1.5 g·L<sup>-1</sup> of potassium dibasic phosphate, 1.5 g·L<sup>-1</sup> of monobasic potassium phosphate, 0.05 g·L<sup>-1</sup> of sodium sulfate nonohydrate and 0.2 g·L<sup>-1</sup> of yeast extract. The nutrient solution was prepared to provide a balanced nutrient condition and to guarantee a reductive redox potential, and its volume changed according to the amount of sulfide solution.

#### D. Operating conditions

The fermenter was fed with Na<sub>2</sub>S·9H<sub>2</sub>O and the S<sup>2-</sup> ion concentration ranged from 50 to 1000 mg·L<sup>-1</sup> (50, 75, 100, 200, 300, 400, 500, 750, 750 and 1000 mg·L<sup>-1</sup>). The effect of these concentrations on the methanogenic activity was studied at pH 7.0 and pH 7.5. The pH was controlled by the addition of 6N NaOH and 1N H<sub>2</sub>SO<sub>4</sub> with a change of 0.5 pH units. Before starting the sulfides addition experiments, the methanogenic activity was evaluated with no concentration of this ion, in order to compare with the results of other experiments.

The volume of the fermenter in all the experiments was composed by biomass (anaerobic sludge), substrate (sodium acetate trihydrate), sodium sulfide nonohydrate and filled up to 5L with nutrient solution. The headspace volume was 2.5 L, thus completing the fermenter volume of 7.5 L.

The biomass and the nutrient solution were kept under a temperature of 35 °C for a minimum of 24 h to metabolize some organic compounds that could be present in the medium prior to the addition of 10% sodium acetate and sulfate concentrations.

#### E. Specific methanogenic activity

The highest tangent method was used to calculate the specific methanogenic activity (SMA). This method consists of modeling the methane production curve (methane volume (mL) vs. time (h)), using an adequate polynomial function. From the derivative of this function, the values of the polynomial curve tangent points are obtained and the highest value of the tangent is used (maximum rate of methane production). This value is divided by the concentration of biomass contained in the digester. The specific velocity of methane production is then expressed by Equation (2).

$$SMA = \frac{\Delta P_{CH_4}}{\Delta t \cdot TVS} \quad (2)$$

where SMA is the specific methanogenic activity (mL CH<sub>4</sub>·mg TVS<sup>-1</sup>·h<sup>-1</sup>), TVS is total volatile solids (mg TVS), ΔP<sub>CH<sub>4</sub></sub> is the cumulative production of CH<sub>4</sub> (mL) and Δt is the time period (h).

#### F. Analytical methods

The analytical methods used for the analysis of the initial parameters and the results of the experiment are presented in Table 2. All analyses of the parameters were performed according to the methodology established in [23].

The biogas produced was measured by the liquid displacement method, which has also been used by other authors [24,25,26]. Alkalized water was used to absorb

carbon dioxide, which allows only the displacement of water by methane. Afterward, the volume of methane produced was normalized to a temperature of 20 °C and a pressure of 1 atm.

### III. RESULTS AND DISCUSSION

#### A. Specific methanogenic activity

The specific methanogenic activity (SMA) tests with different concentrations of sulfide indicated that the SMA

Tab. 2: Methodology of essays used

Parameters	Methodology / Equipment
Total solids	SMEWW-Method 3030-E/3111-B
COD	SMEWW- titrimetric method with closed reflux 5520C
Redox potential	Combined platinum electrode Pt4805-SC-DPAS-K8S of Mettler-Toledo
pH	Combined platinum electrode 405-DPAS-SC-K8 of Mettler-Toledo
Volatile acids	Gas chromatography, Shimadzu GC 2010 plus with column FID DANI DN-FFAP 11448
Composition of biogas	Gas chromatography, DaniMaster AS with column Carboxen <sup>TM</sup> 1006 PLOT Capillary Column (30 m x 0,53 mm), with a thermal conductivity detector (TCD), using nitrogen gas ultra-pure as carrier gas

\*SMEWW: Standard Methods for Examination of Water and Wastewater (2012), 22nd Edition.

values reduce with the increase in the S<sup>2-</sup> ion concentration. The increase in sulfide concentration significantly affected the performance of the methanogenic archaea at the both pH values that were studied. The highest inhibition was observed in the experiments performed at pH equal to 7.5, as it can be observed in the results presented in Figure 2.

At the sulfide concentration of 50 mg S<sup>2-</sup>·L<sup>-1</sup> there was an inhibition of SMA of 37.8% at pH 7.0 and 67.01% at pH 7.5. These results are in agreement with those presented by Rinzeima and Lettinga [11], where at a concentration of 50 mg S<sup>2-</sup>·L<sup>-1</sup> a significant inhibition was observed. In studies carried out by Souza [9], concentrations between 50 and 100 mg S<sup>2-</sup>·L<sup>-1</sup> were considered tolerable.

For the authors Winifrey and Zeikus [12], a concentration of 340 mg S<sup>2-</sup>·L<sup>-1</sup> completely inhibited methane production. However, the results obtained in this article, at a concentration of 300 mg S<sup>2-</sup>·L<sup>-1</sup>, the inhibition was 57.8% at pH 7.0 and 94% at pH 7.5. These results demonstrate the influence of the pH value on the behavior of toxic compounds, since at pH 7.5 the inhibition was practically total, which is similar to the results found by Winifrey and Zeikus [12]. Similar results were found by Khan and Trottier [8], where they reported that a concentration of 290 mg S<sup>2-</sup>·L<sup>-1</sup> inhibits anaerobic digestion.

Koster et al. [14], found in his studies a 50% inhibition with a concentration of 250 mg S<sup>2-</sup>·L<sup>-1</sup>. In the present work, the sulfide concentrations closest to this value were 200 mg·L<sup>-1</sup> and 300 mg·L<sup>-1</sup> for the same pH with inhibitions of 43.7% and 57.8%, respectively. Through interpolation, it

can be estimated that for a concentration of 250 mg.L<sup>-1</sup>, the results are very similar, achieving a SMA reduction of 50.7%.

As noted by Parkin and Speece [13], concentrations between 100 and 150 mg S<sup>2-</sup>.L<sup>-1</sup> led to severe inhibition at pH 6.8 as it was also found in the experiments. In this study, the inhibitions for this two concentrations were 46.1% and 43.7% of reduction in the methanogenic activity at pH 7.0. For the authors Parkin et al. [10], inhibitions by soluble sulfide occurred at concentrations of 100 to 800 mg. L<sup>-1</sup>. When compared to the results obtained at pH 7.0, for a concentration of 50 mg S<sup>2-</sup>.L<sup>-1</sup> there was a 37.8% inhibition of SMA.

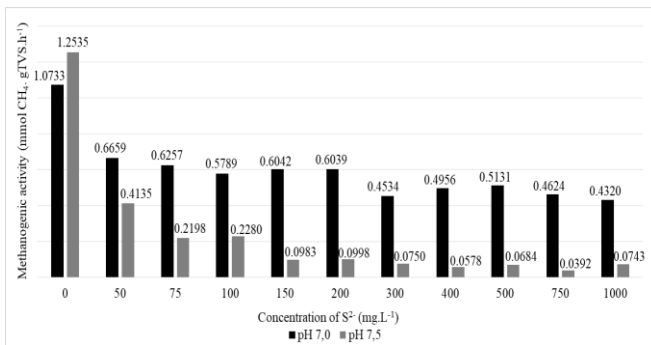

Fig. 2: Specific methanogenic activity results obtained for the tests with pH 7.0 and 7.5 at concentrations of S<sup>2-</sup> ion between 0 and 1000 mg S<sup>2-</sup>.L<sup>-1</sup>.

Kroiss and Plahl-Wabnegg [27], describe in their article that at pH 7.0 the concentration of H<sub>2</sub>S and HS<sup>-</sup> is 50%, while at pH 7.5 it is 75% HS<sup>-</sup> and 25% as H<sub>2</sub>S. This may explain the higher toxicity for the pH 7.5 experiments. Hydrogen sulfide in the gaseous state (50% of it) ends up being dragged together with the biogas formed in the reactor at pH 7.0, which makes it less inhibitory in the process. At pH 7.5, where 75% of HS<sup>-</sup> is present and this gas does not end up being dragged out of the reactor, thus remaining dissolved in the liquid and causing the greatest toxicity in the anaerobic digestion. The pH 7.5 is not close to the optimal condition for acidogenesis (5.5 to 6.5) and with the increase in HS<sup>-</sup> within the medium, becomes toxic to the process and inhibits the growth of methanogenic archaea.

**B. Removal of organic load**

Inhibition by sulfides also affects the removal of the organic load in the process. For pH 7.0 the COD removal for the case without addition of S<sup>2-</sup> concentration was 93.3%, reaching a 49.14% removal for the concentration of 1000 mg S<sup>2-</sup>.L<sup>-1</sup>. At pH 7.5 the COD removal was close to zero, and a COD removal of 80.7% was achieved without any concentration of S<sup>2-</sup>, a removal of 9.6% was observed with the concentration of 1000 mg S<sup>2-</sup>.L<sup>-1</sup>. Figure 3 shows a noticeable decay trend for the two evaluated pH values. For both, pH 7.0 and 7.5, it is observed an oscillation in the results up to 400 mg S<sup>2-</sup>.L<sup>-1</sup>. In this period the process shows to be more unstable without presenting a uniformity of results. This does not happen at concentrations higher than 400 mg S<sup>2-</sup>.L<sup>-1</sup>, with constant COD reduction results. The COD removal results are inversely statistically correlated

with the increase in the S<sup>2-</sup> ratio. At pH 7.0 the correlation index is -0.84 and for pH 7.5 is -0.88.

**C. Reduction in specific methanogenic activity**

The SMA reduction behavior, shown in Figure 4, with increased sulfide concentration is similar for the two pH values studied. However, at pH 7.5 the reductions are higher.

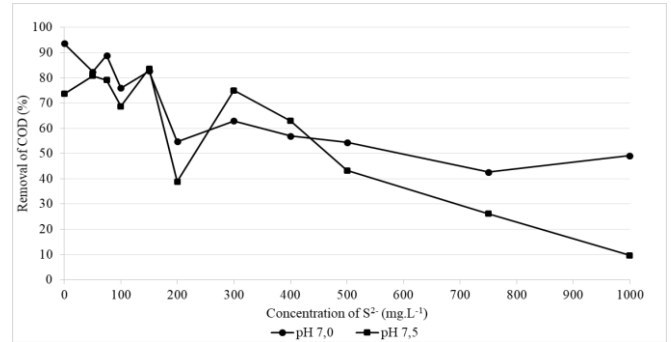

Fig. 3: Removal of COD for each tested concentration of S<sup>2-</sup> and values of pH 7.0 and 7.5.

The concentrations of 50, 75 and 100 mg S<sup>2-</sup>.L<sup>-1</sup> of S<sup>2-</sup> initially tested for the two pH values assessed promoted the greatest increase in the reduction of SMA. When observed at pH 7.0 the reductions were 37.96%, 41.70%, and 46.06% respectively for the aforementioned concentrations. At pH 7.5 the reductions were 67.01%, 82.47%, and 81.81% respectively for the same concentrations. From the concentration of 150 mg S<sup>2-</sup>.L<sup>-1</sup> to pH 7.0 the increment in the reduction of the SMA is minimal, tending to an average value of 52.56% and thus obtaining at the concentration of 1000 mg S<sup>2-</sup>.L<sup>-1</sup> a reduction of 59.75%.

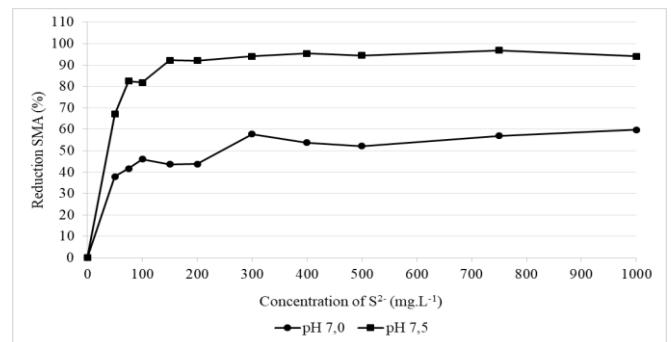

Fig. 4: Reduction of the SMA for each tested concentration of S<sup>2-</sup> and for the values of pH 7.0 and 7.5

For the pH value of 7.5, the reduction values from the concentration of 150 mg S<sup>2-</sup>.L<sup>-1</sup> already demonstrate a constant effect concerning the reduction of the SMA. The reduction of the SMA from this sulfide concentration had changed very little, having an average of 94.15%. For a concentration of 1000 mgS<sup>2-</sup>.L<sup>-1</sup>, there was a reduction of 94.07%, thus demonstrating that practically no methanogenic activity occurs in this concentration.

**D. Inhibition in the vinasse anaerobic digestion**

Using the concentrations found in the literature for sulfates quantity present in the vinasse (1300 to 5000 mg SO<sub>4</sub><sup>2-</sup>.L<sup>-1</sup>)

and the equation of the overall sulfur reduction process (Equation 1), it is possible to know the maximum and minimum concentration of sulfide that can be present in the anaerobic digestion of vinasse. Thus, through the results obtained in this article, it is possible to verify the expected inhibition of the process. For the case of the lowest concentration found in the literature,  $1,300 \text{ mg SO}_4^{2-}\cdot\text{L}^{-1}$ , the conversion to sulfides is in the order of  $430 \text{ mg S}^{2-}\cdot\text{L}^{-1}$ . Through calculated interpolation results it is expected an inhibition of 51.1 % of the methanogenic activity. If the highest concentration in the literature,  $5,000 \text{ mg SO}_4^{2-}\cdot\text{L}^{-1}$ , was considered, the expected sulfide concentration would correspond to  $1,667 \text{ mg S}^{2-}\cdot\text{L}^{-1}$ , which would result in a 71.02% inhibition of the methanogenic activity. The organic load removal in the process at these concentrations would correspond to 56.7% for the concentration of  $430 \text{ mg S}^{2-}\cdot\text{L}^{-1}$  and 9.7% for the concentration of  $1,667 \text{ mg S}^{2-}\cdot\text{L}^{-1}$ . Results were evaluated taking into consideration those obtained in the experiments at a pH equal to 7.0.

#### IV. CONCLUSIONS

All the concentrations of sulfide assessed in this article showed inhibitions of the methanogenic activity. Inhibitions of the SMA for the pH 7.0 were in the range of 38.5% to 59.8% and for pH 7.5 from 67% to 94%, results for the lowest evaluated concentration of  $50 \text{ mg S}^{2-}\cdot\text{L}^{-1}$  and for the highest of  $1,000 \text{ mg S}^{2-}\cdot\text{L}^{-1}$ . The pH is another characteristic to be monitored in these systems. At pH 7.5 there are higher concentrations of dissolved  $\text{HS}^-$ , creating toxicity in the medium and inhibiting the growth of methanogenic archaea. Another undesirable finding of this study was the low removal of COD when treating sulfate-rich effluents. For the test at pH 7.0, the removal of COD in the experiment without the addition of any concentration of  $\text{S}^{2-}$  was 93.3%, decreasing to 49.14% removal with concentrations of  $1000 \text{ mg S}^{2-}\cdot\text{L}^{-1}$ . This demonstrates that sulfates must be removed from anaerobic digestion processes when higher methane yields are sought.

#### V. REFERENCES

- 1.ANP. (2016) Agência Nacional do Petróleo, Gás Natural e Biocombustíveis, Boletim do Etanol Nº 06/2016. Available in: [www.anp.gov.br/?pg=79694&m=&t1=&t2=&t3=&t4=&ar=&ps=&142185944140](http://www.anp.gov.br/?pg=79694&m=&t1=&t2=&t3=&t4=&ar=&ps=&142185944140). Rio de Janeiro: ANP.
- 2.FERRAZ, A. D. N. J.; ETCHEBEHERE, C.; ZAIAT, M. Mesophilic hydrogen production in acidogenic packed-bed reactors (APBR) using raw sugarcane vinasse as substrate: Influence of support materials. *Anaerobe*, v. 34, n. 94-105, 2015.
- 3.JANKE, L.; LEITE, A. F.; BATISTA, K.; SILVA, W.; NIKOLAUSZ, M.; NELLES, M.; STINNER, W. Enhancing biogas production from vinasse in sugarcane biorefineries: Effects of urea and trace elements supplementation on process performance and stability. *Bioresource Technology*, v. 217, p. 10-20, 2016.
- 4.BARRERA, E. L.; SPANJERS, H.; ROMERO, O.; ROSA, E.; DEWULF, J. Characterization of the sulfate reduction process in the anaerobic digestion of a very high strength and sulfate rich vinasse. *Chemical Engineering Journal*, v. 248 , p. 383-393, 2014.
- 5.COLLERAN, E.; FINNEGAN, S.; LENS, P. Anaerobic treatment of sulphate-containing waste streams. *Antonie van Leeuwenhoek*, v. 67, p. 29-46, 1995.
- 6.YUAN, H; ZHU, N. Progress in inhibition mechanisms and process control of intermediates and by-products in sewage sludge anaerobic digestion. *Renewable and Sustainable Energy Reviews*, v. 58, p. 429-438, 2016.
- 7.HARADA, H.; UEMURA, S.; MONOMOI, K. Interactions between sulphate-reducing bacteria and methane-producing bacteria in UASB reactors fed with low strength wastes containing different levels of sulphate. *Water Res*, v. 28, p. 355-367, 1994.
- 8.KHAN, A. W.; TROTTIER, T. M. Effect of sulfur-containing compounds on anaerobic degradation of cellulose to methane by mixed cultures obtained from sewage sludge. *Environmental Microbiology*, n. 6, v. 35, p. 1027-1034, 1978.
- 9.SOUZA, M. E. Fatores que influenciam a digestão anaeróbia. *Revista DAE*, n. 137, v. 44, p. 88-94, 1984.
- 10.PARKIN, G. F. LYNCH, N. A.; KUO, W.; KEUREN E. L. V.; BHATTACHARYA, S. K. Interaction between sulfate reducers and methanogens fed acetate and propionate. *Res. J. Water Pollut. Control Fed.*, v. 62, p. 780-788, 1990.
- 11.RINZEMA, A.; LETTINGA, G. (1988). The Effect of Sulfide on The Anaerobic Degradation of Propionate. *Environ. Technol. Lett.*, v. 9, p. 83, 1988.
- 12.WINIFREY, M. R.; ZEIKUS, J. G. Effect of sulfate on carbon and electron flow during microbial methanogenesis in fresh water sediments. *Env. Microbiology*, v. 33, p. 275-281, 1977.
- 13.PARKIN, G. F.; SPEECE, R. E. Attached versus suspended growth anaerobic reactors: response to toxic substances. *Water Sci Technol*, v. 15, p. 261-289, 1983.
- 14.KOSTER. I. W.; RINZEMA, A.; DE VEGT, A. L.; LETTINGA, G. Sulfide inhibition of the methanogenic activity of granular sludge at various pH levels. *Water Res.*, v. 20, p. 1561-1567, 1986.
- 15.HATI, K. M.; Biswas, A. K.; Bandyopadhyay, K. K.; Misra, A. K. Soil properties and crop yields on a vertisol in India with application of distillery effluent. *Soil and Tillage Research*, v. 92, n. 1-2, p. 60-68, 2007.
- 16.GOYAL, S. K.; SETH, R.; HANDA, B. K. Diphasic fixed-film biomethanation of distillery spentwash. *Bioresource Technology*, v. 56, n. 2-3, p. 239-244, 1996.
- 17.RAIS, M.; SHEORAN, A. Treatment of Sugarcane Technology issues Effluents: Major Producing States in India. v. 5, n. 1, p. 11-19, 2015.
- 18.FERREIRA, L. F. R. AGUIAR, M. M.; MESSIAS, T. G.; POMPEU, G. B.; LOPEZ, A. M. Q.; SILVA, D. P.; MONTEIRO, R. T. Evaluation of sugar-cane vinasse treated with *Pleurotus sajor-caju* utilizing aquatic organisms as toxicological indicators. *Ecotoxicology and Environmental Safety*, v. 74, n. 1, p. 132-137, 2011.
- 19.GIBERT, O.; PABLO, J.; CORTINA, J. L.; AYORA, C. Treatment of acid mine drainage by sulphate-reducing bacteria using permeable reactive barriers: A review from laboratory to full-scale experiments. *Environmental Science & Bio/Technology*, v. 1, p. 327-333, 2002.
- 20.BUDIYONO; SYAICHURROZI I.; SUMARDIONO, S. Biogas production from bioethanol waste: the effect of pH and urea addition to biogas production rate. *Waste Tech.*, v. 1, p. 1-5, 2013.

21. O'FLAHERTY, V.; MAHONY, T.; O'KENNEDY, R.; COLLERAN, E. Effect of pH on growth kinetics and sulphide toxicity thresholds of a range of methanogenic, syntrophic and sulphate-reducing bacteria. *Process Biochem.*, v. 33, p. 555-569, 1998.
22. VISSER, A.; NOZHEVNIKOVA, A. N.; LETTINGA, G. Sulphide inhibition of methanogenic activity at various pH levels at 55°C. *Chemical Technology and Biotechnology*, v. 57, p. 9-13, 1993.
23. APHA. (2012) Standard methods for the examination of water and wastewater. Anais...Washington: American Public Health Association.
24. BUDIYONO, I. N.; WIDIASA, S. J.; SUNARSO. The kinetic of biogas production rate from cattle manure in batch mode. *International Journal of Chemical and Biological Engineering*, v. 3, n. 1, p. 39-44, 2010.
25. SYAICHURROZI, I.; BUDIYONO; SUMARDIONO, S. Predicting kinetic model of biogas production and biodegradability organic materials: Biogas production from vinasse at variation of COD/N ratio. *Bioresource Technology*, v. 149, p. 390-397, 2013.
26. YUSUF, M. O. L.; IFY, N. L. The effect of waste paper on the kinetics of biogas yield from the co-digestion of cow dung and water hyacinth. *Biomass and Bioenergy*, v. 35, p. 1345-1351, 2011.
27. KROISS, H.; PLAHL-WABNEGG, F. Sulfide Toxicity with anaerobic waste water treatment. *Anaerobic waste water treatment - Proceedings of the European Symposium*, 1983.